The Planning and Zoning Commission will meet in a regular session on Wednesday, February 11, 2026, at 6:00 p.m. in the City Council Chambers, 9400 Municipal Parkway, Garden Ridge, Texas. This is an open meeting, open to the public, subject to the Open Meetings Law of the State of Texas, and as required by law, notice is hereby posted providing time, place, date, and agenda thereof. The meeting facility is wheelchair accessible and accessible parking spaces are provided. Requests for accommodations or interpretative services must be made to the City Secretary 48 hours prior to this meeting.

1. CALL TO ORDER/ROLL CALL**2. PLEDGE OF ALLEGIANCE****3. CITIZEN COMMENT PERIOD**

The Commission welcomes citizen participation and comments at all Commission Meetings. First Citizen Comment Period: Speakers are required to sign up to speak before the meeting and shall limit their comments to three (3) minutes each. Second Citizen Comment Period: Speakers are not required to sign up to speak and shall limit their comments to two (2) minutes each. Speakers are only allowed to speak once per topic, unless also speaking during a posted Public Hearing. If you speak, you must follow these guidelines:

- 3.1. Direct your comments to the entire Commission, not to an individual member, nor to the audience.
- 3.2. Show the Commission the same respect that you would like to be shown.
- 3.3. State your name and address before your comments begin.
- 3.4. The Commission may not discuss or take action on any presented issue.
- 3.5. Topics of operational concern shall be directed to the City Manager.

NOTE: The Texas Open Meetings Act permits a member of the public or a member of the governmental body to raise a subject that has not been included in the notice for the meeting. However, any discussion of the subject must be limited to a proposal to place the subject on the agenda for a future meeting and any response to a question posed to the City Council is limited to either a statement of specific factual information or a recitation of existing policy. TEX. GOV'T CODE § 551.042.

4. BUSINESS ITEMS

The following items are for discussion, consideration, and action.

- 4.1. Approval of Minutes for November 12, 2025, Planning and Zoning Commission Regular Meeting.
- 4.2. Items applicable to the Planning and Zoning Commission discussed at City Council meetings.
- 4.3. Preliminary Plat establishing Grace Covenant Church, being a total of 2.826 acres inclusive of 0.0446 acre right-of-way dedication establishing Lot 1, Block 1, Garden Ridge, Comal County, Texas, and being that same property conveyed by special warranty deed with vendor's lien to Grace Covenant Presbyterian Church recorded in document #202406004783 of the official public records of Comal County, Texas.
- 4.4. Subdivision Ordinance.
- 4.5. Future Agenda Items.

5. CITIZEN COMMENT PERIOD (See Guidelines under Item 3.)**6. ADJOURNMENT**

AGENDA NOTICES:

Decorum Required: Any disruptive behavior, including shouting or derogatory statements or comments may be ruled out of order by the Presiding Officer. Continuation of this type of behavior could result in a request by the Presiding Officer that the individual leave the meeting, and if refused, an order of removal.

Action by Commission Authorized: The Commission may vote or act upon any item within this Agenda.

Attendance By Other Elected or Appointed Officials: It is anticipated that members of the City Council, other city boards, commissions, and/or committees may attend the meeting in numbers that may constitute a quorum of the other city boards, commissions, and/or committees. Notice is hereby given that the meeting, to the extent required by law, is also noticed as a meeting of the City Council, other boards, commissions, and/or committees of the City, whose members may be in attendance. The members of the boards, commissions, and/or committees may participate in discussions on the same items listed on the agenda, which occur at the meeting, but no action will be taken by such in attendance unless such item and action are specifically provided for on an agenda for that board, commission, or committee subject to the Texas Open Meetings Act.

This is to certify that I, Marisa Spencer, posted this Agenda at 1:00 p.m. on February 4, 2026, on the bulletin board located at the entrance to Garden Ridge City Hall, 9400 Municipal Parkway, Garden Ridge, Texas.

Marisa Spencer

Marisa Spencer
City Secretary

Commissioners Present:

Chair Kerim Jacaman
Vice-Chair Karen Diaz
Commissioner Joe Maloney
Commissioner Richard Howard
Commissioner Darren Bates

Commissioners Absent:

Vacant Position
Vacant Position

City Staff and City Councilmembers Present:

Ryan Rapelye, City Manager
Marisa Spencer, City Secretary
Cyndi Simmons, Assistant City Secretary
Dan Jones, City Attorney
Hank Crippen, City Engineer

1. Call to Order/Roll Call

With a quorum of the Planning and Zoning Commissioners present, Chair Jacaman called the regular meeting of the Garden Ridge Planning and Zoning Commission to order at 6:00 p.m. on Wednesday, November 12, 2025, in the City Council Chambers of Garden Ridge City Hall, 9400 Municipal Parkway, Garden Ridge, Texas 78266.

2. Pledge of Allegiance

Chair Jacaman led the Pledge of Allegiance.

3. Citizen Comment Period:

No one signed up to speak.

4. Business Items

The following items are for discussion, consideration, and action.

a) Approval of Minutes for October 8, 2025, Planning and Zoning Commission Regular Meeting.

Motion: A motion was made by Vice-Chair Diaz, seconded by Commissioner Bates, to approve the Minutes for October 8, 2025, Planning and Zoning Commission Regular Meeting. The Commission voted four (4) for and none (0) opposed. The motion carried unanimously.

b) Items applicable to the Planning and Zoning Commission discussed at City Council meetings.

Chair Jacaman provided the Commission with an update on items applicable to the Planning and Zoning Commission discussed at City Council Meetings.

c) Per Article V of Ordinance No. 7, the plat shall be drawn to a scale of one (1) inch to one-hundred (100) feet [1"=100'], pursuant to Article III of Ordinance No. 7, the applicant may request a Scale Variance, consider granting applicant's Scale Variance Request of one (1) inch to sixty (60) feet [1"=60'] for the Replat of 8111 Wild Wind Park, being a 1.824 acre tract of land, establishing Lot 91R, comprised of Lots 91 & 92 of the Wild Wind Unit-3 Subdivision Plat, recorded in doc # 202306029451 of the map and plat records of Comal County, Texas.

City Manager Ryan Rapelye and City Engineer Hank Crippen spoke regarding the Scale Variance Request for the Replat of 8111 Wild Wind Park and addressed questions from Commissioners.

Motion: A motion was made by Commissioner Maloney, seconded by Commissioner Bates, to recommend to City Council approval of the Scale Variance Request of one (1) inch to sixty (60) feet [1"=60'] for the Replat of 8111 Wild Wind Park and approval of the Replat of 8111 Wild Wind Park as presented, being a 1.824 acre tract of land, establishing Lot 91R, comprised of Lots 91 & 92 of the Wild Wind Unit-3 Subdivision Plat, recorded in doc # 202306029451 of the map and plat records of Comal County, Texas. The Commission voted four (4) for and none (0) opposed. The motion carried unanimously.

d) Ordinance No. 210-102022 An Ordinance of the City Council of the City of Garden Ridge, Texas, adopting board and commission policies and procedures; providing a cumulative and savings clause; providing for severability; and declaring an effective date.

1. Appointment of Planning and Zoning Commission Chair and Vice-Chair for a one-year term.

The Commission discussed the roles and responsibilities of Chair and Vice-Chair.

Motion: A motion was made by Vice-Chair Diaz, seconded by Commissioner Bates, to appoint Commissioner Jacaman as Chair for a one-year term. The Commission voted four (4) for and none (0) opposed. The motion carried unanimously.

Motion: A motion was made by Commissioner Maloney, seconded by Commissioner Bates, to appoint Commissioner Howard as Vice-Chair for a one-year term. The Commission voted four (4) for and none (0) opposed. The motion carried unanimously.

e) Future Agenda Items.

None at this time.

5. Citizen Comment Period

No one wished to speak.

6. Adjournment

There being no further business, the Wednesday, November 12, 2025, Planning and Zoning Commission Regular Meeting was adjourned at 6:15 p.m. by Chair Jacaman.

ATTEST:

Kerim Jacaman
Chair

Marisa Spencer
City Secretary



January 23, 2026

Mr. Scott Dye, P.E., R.P.L.S.
Dye Enterprises
4047 Stahl Road #3
San Antonio, TX 78217

RE: City of Garden Ridge Review 4 – Grace Covenant Church Preliminary Plat Approval

Dear Mr. Dye:

Trihydro Corporation (Trihydro) has completed its review of the Grace Covenant Church Preliminary Plat application on behalf of the City of Garden Ridge. Based on our evaluation, the preliminary plat complies with the requirements of City of Garden Ridge Ordinance 13-10-2024, and is recommended for approval.

This approval does not negate any state or other regulatory entity requirements. Any changes made to the preliminary plat subsequent to this approval will require additional review and approval by the City of Garden Ridge. If you have any questions, please contact me at (830) 626-3588.

Sincerely,
Trihydro Corporation

A handwritten signature in black ink, appearing to read "H. Crippen", is written over a light gray signature line.

Hank Crippen, P.E., CFM

GARDE-025-0007

cc: Ryan Rapelye, City of Garden Ridge, City Manager

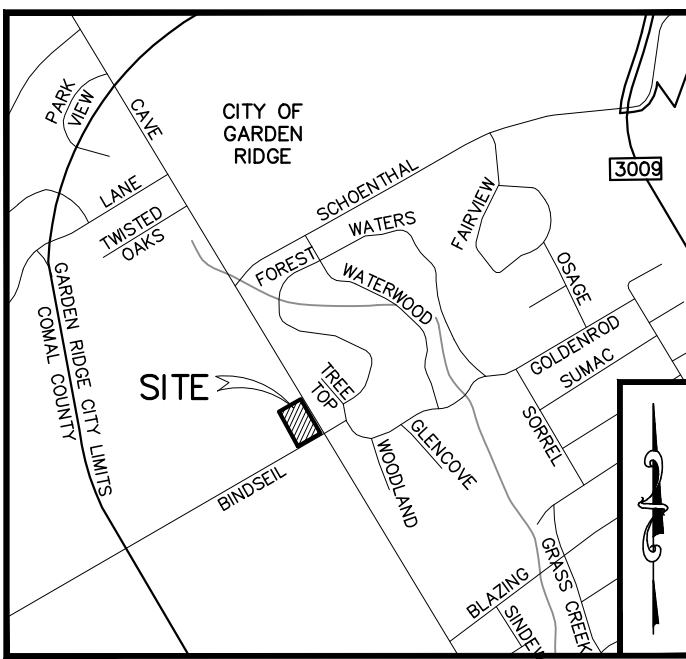

LOCATION MAP
SCALE: 1"=2000'

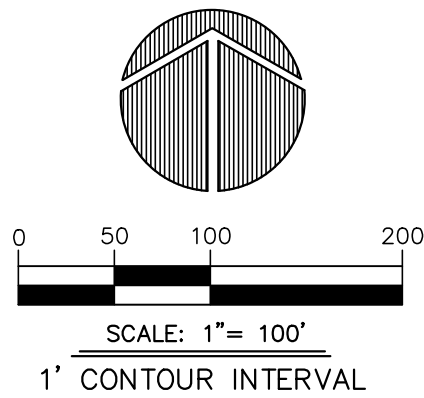

LINE DATA		
NO.	BEARING	LENGTH
LI	S15°00'49"W	44.71'

LEGEND

- FOUND 1/2" STEEL REBAR (UNLESS NOTED OTHERWISE)
- SET 1/2" STEEL REBAR WITH YELLOW CAP MARKED "DYE ENT SATX"
- O.P.R. OFFICIAL PUBLIC RECORDS OF COMAL COUNTY, TEXAS
- D.R. DEED RECORDS OF COMAL COUNTY, TEXAS
- M.P.R. MAP AND PLAT RECORDS OF COMAL COUNTY, TEXAS
- 449/739 VOLUME/PAGE
- C.M. CONTROLLING MONUMENT
- 6.36 — EXISTING CONTOUR
- B.S.L. BUILDING SETBACK LINE
- G.E.T.V.E. GAS, ELECTRIC, TELEPHONE, & CABLE T.V. EASEMENT
- U.E. UTILITY EASEMENT

STATE OF TEXAS
COUNTY OF BEXAR

I HEREBY CERTIFY THAT PROPER ENGINEERING CONSIDERATION HAS BEEN GIVEN THIS PLAT TO MATTERS OF STREETS, LOTS AND DRAINAGE LAYOUT.

LICENSED PROFESSIONAL ENGINEER NO. 84635

SWORN TO AND SUBSCRIBED BEFORE ME THIS THE ____ DAY OF _____, _____

NOTARY PUBLIC IN AND FOR THE STATE OF TEXAS

STATE OF TEXAS
COUNTY OF BEXAR

I HEREBY CERTIFY THAT THIS PLAT IS TRUE AND CORRECT AND WAS PREPARED FROM AN ACTUAL SURVEY OF THE PROPERTY MADE ON THE GROUND UNDER MY SUPERVISION.

REGISTERED PROFESSIONAL LAND SURVEYOR NO. 5315

SWORN TO AND SUBSCRIBED BEFORE ME THIS THE ____ DAY OF _____, _____

NOTARY PUBLIC IN AND FOR THE STATE OF TEXAS

CPS ENERGY NOTES:

- THE CITY OF SAN ANTONIO AS PART OF ITS ELECTRIC AND GAS SYSTEM (CITY PUBLIC SERVICE BOARD) IS HEREBY DEDICATED THE EASEMENTS AND RIGHTS-OF-WAY FOR ELECTRIC AND GAS DISTRIBUTION AND SERVICE FACILITIES IN THE AREAS DESIGNATED ON THIS PLAT AS "ELECTRIC EASEMENT", "GAS EASEMENT", "ANCHOR EASEMENT", "SERVICE EASEMENT", "OVERHANG EASEMENT", "UTILITY EASEMENT", AND "TRANSFORMER EASEMENT" FOR THE PURPOSE OF INSTALLING, CONSTRUCTING, RECONSTRUCTING, MAINTAINING, REMOVING, INSPECTING, PATROLLING, AND ERECTING POLES, HANGING OR BURYING WIRES, CABLES, CONDUITS, PIPELINES OR TRANSFORMERS, EACH WITH ITS NECESSARY APPURTENANCES, TOGETHER WITH THE RIGHT OF INGRESS AND EGRESS OVER GRANTOR'S ADJACENT LAND, THE RIGHT TO RELOCATE SAID FACILITIES WITHIN SAID EASEMENT AND RIGHT-OF-WAY AREAS, AND THE RIGHT TO REMOVE FROM SAID LANDS ALL TREES OR PARTS THEREOF, OR OTHER OBSTRUCTIONS WHICH ENDANGER OR MAY INTERFERE WITH THE EFFICIENCY OF SAID LINES OR APPURTENANCES THERETO. IT IS AGREED AND UNDERSTOOD THAT NO BUILDINGS, CONCRETE SLABS, OR WALLS WILL BE PLACED WITHIN SAID EASEMENT AREAS.
- ANY CPS MONETARY LOSS RESULTING FROM MODIFICATIONS REQUIRED OF CPS EQUIPMENT, LOCATED WITHIN SAID EASEMENT, DUE TO GRADE CHANGES OR GROUND ELEVATION ALTERATIONS SHALL BE CHARGED TO THE PERSON OR PERSONS DEEMED RESPONSIBLE FOR SAID GRADE CHANGES OR GROUND ELEVATION ALTERATION.
- THIS PLAT DOES NOT AMEND, ALTER, RELEASE OR OTHERWISE AFFECT ANY EXISTING ELECTRIC, GAS, WATER, SEWER, DRAINAGE, TELEPHONE, CABLE EASEMENTS OR ANY OTHER EASEMENTS FOR UTILITIES UNLESS THE CHANGES TO SUCH EASEMENTS ARE DESCRIBED BELOW.

SURVEYOR'S NOTES:

THE BEARINGS SHOWN ARE BASED ON THE NORTH AMERICAN DATUM OF 1983 (NAD83) STATE PLANE TEXAS SOUTH CENTRAL ZONE NAD83 (2011 ADJUSTMENT).

CITY NOTES:

- NOTICE: SELLING A PORTION OF THIS ADDITION BY METES AND BOUNDS IS A VIOLATION OF CITY ORDINANCES AND STATE LAW AND IS SUBJECT TO FINES AND WITHHOLDING OF UTILITIES AND PERMITS.
- ACCORDING TO FLOOD INSURANCE RATE MAP, PANEL 48091C0415E, DATED SEPTEMBER 2, 2009, THE PROPERTY IS LOCATED IN ZONE "X", AND IS NOT WITHIN THE 100-YEAR FLOODPLAIN.
- ALL OPEN SPACE, COMMON AREAS, GREENBELTS, DRAINAGE EASEMENTS OR OTHER AREAS IDENTIFIED AS PRIVATE SHALL BE THE RESPONSIBILITY OF OWNER OR OWNERS SUCCESSORS AND/OR ASSIGNS PROVIDED SUCH SUCCESSOR OR ASSIGN IS APPROVED BY THE CITY.
- THIS PROPERTY LIES IN THE COMAL INDEPENDENT SCHOOL DISTRICT
- THIS PROPERTY LIES IN THE CITY LIMITS OF THE CITY OF GARDEN RIDGE.
- THIS PROPERTY LIES WITHIN THE FOLLOWING SERVICE AREAS:
ELECTRIC - CPS ENERGY
TELEPHONE - AT&T
WATER - CITY OF GARDEN RIDGE
SEWER - INDIVIDUAL ON-SITE SEWAGE FACILITY
- PROPERTY OWNERS ARE RESPONSIBLE FOR MAINTENANCE OF DEDICATED EASEMENTS ON THEIR PROPERTY AND SHALL NOT UTILIZE THESE EASEMENTS FOR ANY PURPOSE DETRIMENTAL TO THEIR INTENDED USE (I.E., NO STRUCTURES, SEPTIC TANK FIELDS, ETC.). GRANTEES OF SAID DEDICATED EASEMENTS RESERVE THE RIGHT OF ACCESS TO SUCH EASEMENTS.
- UTILITIES SHALL HAVE ACCESS TO THE METER LOCATIONS FROM THE FRONT YARD AND METER LOCATIONS SHALL NOT BE LOCATED WITHIN A FENCED AREA.
- EACH LOT MUST HAVE ITS OWN WATER AND SEWER SERVICE AT THE OWNER'S/DEVELOPER'S EXPENSE.
- DO NOT COMBINE ANY NEW UTILITY EASEMENTS WITH DRAINAGE EASEMENTS OR MAKE CHANGES IN GRADE WITHIN THE UTILITY EASEMENT WITHOUT WRITTEN APPROVAL FROM THE CITY OF GARDEN RIDGE.
- THE CITY OF GARDEN RIDGE IS NOT RESPONSIBLE FOR DAMAGES TO PROPERTY IMPROVEMENTS LANDSCAPING, TREES, PAVEMENT, SIGNS, DRAINAGE STRUCTURES, PRIVATE UTILITIES, ETC.) THAT ARE PLACED IN ANY TYPE OF UTILITY EASEMENT. TO ENSURE NO CONFLICTS EXIST WITH UTILITY INFRASTRUCTURE IN THE EASEMENT, ALL SUCH IMPROVEMENTS PLACED IN ANY TYPE OF UTILITY EASEMENT MUST BE REVIEWED AND APPROVED THROUGH THE CITY OF GARDEN RIDGE.
- PARKING AND OTHER PERMANENT PAVED SURFACES SHALL NOT BE PLACED WITHIN 15 FEET FROM THE BAT CAVE ROAD RIGHT-OF-WAY WITHOUT CITY APPROVAL.

PRELIMINARY PLAT ESTABLISHING
GRACE COVENANT CHURCH

BEING A TOTAL OF 2.826 ACRES INCLUSIVE OF 0.0446 ACRE RIGHT-OF-WAY DEDICATION ESTABLISHING LOT 1, BLOCK 1, GARDEN RIDGE, COMAL COUNTY, TEXAS.

BEING THAT SAME PROPERTY CONVEYED BY SPECIAL WARRANTY DEED WITH VENDOR'S LIEN TO GRACE COVENANT PRESBYTERIAN CHURCH RECORDED IN DOCUMENT #202406004783, OFFICIAL PUBLIC RECORDS, COMAL COUNTY, TEXAS

PREPARED BY:

DYE ENTERPRISES
ENGINEERS • SURVEYORS • PLANNERS
TBPE, FIRM REGISTRATION #F-2257
TBPLS, FIRM REGISTRATION #10087900
4047 STAHL ROAD, SUITE #3
SAN ANTONIO, TEXAS 78217
TEL (210) 599-4123
FAX (210) 599-4191

DATE OF PREPARATION: 01/21/26

STATE OF TEXAS
COUNTY OF BEXAR

THE OWNER OF LAND SHOWN ON THIS PLAT, AND WHOSE NAME IS SUBSCRIBED HERETO, AND IN PERSON OR THROUGH A DULY AUTHORIZED AGENT, DEDICATES TO GARDEN RIDGE, TEXAS, FOR USE OF THE PUBLIC FOREVER ALL STREETS, ALLEYS, PARKS, WATERCOURSES, DRAINS, EASEMENTS, IN ALL OF THE AFORESAID PUBLIC PLACES AND ALL OTHER PUBLIC PLACES THEREON SHOWN FOR THE PURPOSE AND CONSIDERATION THEREIN EXPRESSED.

OWNER/SUBDIVIDER: GRACE COVENANT PRESBYTERIAN CHURCH
19311 F.M. 2252, SUITE 103
SAN ANTONIO, TX 78266
(210) 651-3851

STATE OF TEXAS
COUNTY OF BEXAR

BEFORE ME, THE UNDERSIGNED AUTHORITY ON THIS DAY PERSONALLY APPEARED _____ KNOWN TO ME TO BE THE PERSON WHOSE NAME IS SUBSCRIBED TO THE FOREGOING INSTRUMENT, AND ACKNOWLEDGED TO ME THAT HE EXECUTED THE SAME FOR THE PURPOSES AND CONSIDERATIONS THEREIN EXPRESSED AND IN THE CAPACITY THEREIN STATED.

GIVEN UNDER MY HAND AND SEAL OF OFFICE THIS ____ DAY OF _____ A.D., 20__

NOTARY PUBLIC, BEXAR COUNTY, TEXAS

THE CITY ENGINEER OF THE CITY OF GARDEN RIDGE, COMAL COUNTY, TEXAS, HEREBY CERTIFIES THAT THIS SUBDIVISION PLAT CONFORMS TO ALL THE REQUIREMENTS OF THE SUBDIVISION REGULATIONS OF THE CITY AS TO WHICH HIS APPROVAL IS REQUIRED.

CITY ENGINEER

THIS PLAT OF GRACE COVENANT CHURCH HAS BEEN SUBMITTED TO AND CONSIDERED BY THE CITY COUNCIL OF GARDEN RIDGE, TEXAS, AND IS HEREBY APPROVED BY SUCH COUNCIL.

DATED THIS ____ DAY OF _____ A.D., 20__

BY: _____
MAYOR

BY: _____
CITY SECRETARY

STATE OF TEXAS
COUNTY OF COMAL

I, _____, COUNTY CLERK OF SAID COUNTY, DO HEREBY CERTIFY THAT THE FOREGOING INSTRUMENT OF WRITING WITH ITS CERTIFICATE OF AUTHENTICATION WAS FILED FOR RECORD IN MY OFFICE ON THE ____ DAY OF _____, A.D. 20__, AT _____, M. IN THE RECORDS OF DEEDS AND PLATS OF SAID COUNTY, IN BOOK VOLUME _____, ON PAGE _____.

IN TESTIMONY THEREOF, WITNESS MY HAND AND OFFICIAL SEAL OF OFFICE, THIS ____ DAY OF _____, A.D. 20__

COUNTY CLERK, COMAL COUNTY, TEXAS

BY: _____

Subdivision Ordinance

City of Garden Ridge, Texas



TABLE OF CONTENTS

Section 1. General.....	4
Sec.1.1. Short title	4
Sec.1.2. Purpose and applicability.....	4
Sec.1.3. Consistency with city master plan and transportation plan	5
Sec.1.4. Definitions	5
Sec.1.5. Public facilities required.....	10
Sec.1.6. Rough proportionality and fair share.....	10
Sec.1.7. Vested rights	10
Sec.1.8. Unauthorized subdivisions or developments	12
Sec.1.9. Development manual.....	13
Sec.1.10. Public works specification manual.....	13
Sec.1.11. Interpretation and conflicts between regulations.....	13
Sec.1.12. Violations and penalties.....	14
Sec.1.13. Validity	14
Section 2. Procedures	14
Sec.2.1. General.....	14
Sec.2.2. Initiation of application.....	15
Sec.2.3. Pre-application conference.....	16
Sec.2.4. Certification of exhibits.....	16
Sec.2.5. Subdivision master plan.....	17
Sec.2.6. Preliminary plat.....	19
Sec.2.7. Final plat.....	21
Sec.2.8. Minor plat	23
Sec.2.9. Amending plat.....	24
Sec.2.10. Replat.....	26
Sec.2.11. Reserved.....	29
Sec.2.12. Vacating a plat.....	29
Sec.2.13. Recordation.....	30
Sec.2.14. Plat waivers	30
Sec.2.15. Public infrastructure construction plans.....	31
Sec.2.16. Public infrastructure permit, inspections, and acceptance of public infrastructure	33

Sec.2.17. Subdivision improvement agreements 34

Section 3. Design Standards..... 36

 Sec.3.1. Monuments and lot markers 36

 Sec.3.2. Blocks 36

 Sec.3.3. Lots 36

 Sec.3.4. Access management 37

 Sec.3.5. Sidewalks..... 38

 Sec.3.6. Alleys 38

 Sec.3.7. Streets 39

 Sec.3.8. Traffic impact analysis..... 44

 Sec.3.9. Water utility 45

 Sec.3.10. Wastewater utility..... 46

 Sec.3.11. Easements 47

 Sec.3.12. Drainage and stormwater 49

 Sec.3.13. Flood hazards 52

 Sec.3.14. Parkland dedication requirements 53

DRAFT

Section 1. General

Sec.1.1. Short title

- A. This ordinance shall be known and may be cited as “The Subdivision Ordinance of the City of Garden Ridge, Texas” or the “Garden Ridge Subdivision Ordinance”.

Sec.1.2. Purpose and applicability

- A. It is the purpose of this ordinance to promote sound planning in the development and subdivision of land, and to provide consistent rules, which protect the public health, safety, and welfare while allowing the legal division of land. The regulations herein have been made after careful study of existing local conditions and the desirable future development of the City. It is not the desire or the intent of the City to control the design of subdivisions of property and its environs, but rather to recommend the utilization, to the fullest extent possible, of good, sound, modern subdivision planning principles.
- B. It is intended that as much freedom as possible be allowed for individual owners and subdividers in the design and ultimate development of new subdivisions so that they will contribute innovation, individuality, and character to the community's new residential neighborhoods and non-residential developments. At the same time, these rules are intended to ensure that such development provides for:
 - 1. the promotion of the health, safety, morals, or general welfare of the City and the safe, orderly, and healthful development of the City
 - 2. adequate major and secondary traffic thoroughfares and public facilities;
 - 3. minimum standards for public facilities
 - 4. a consistent and equitable pattern of development among neighboring parcels of land; and
 - 5. consistency with the City's adopted plans.
- C. On or after the passage of this ordinance, any person, firm, or corporation (subdivider) seeking approval of any plat, plan, or replat of any subdivision of land within the City and its legally established extraterritorial jurisdiction shall be required to comply with the requirements of this ordinance before such approval may be granted. Any subdivision construction plans that have not been approved by the City before the passage of this ordinance shall be required to comply with the requirements of this ordinance. No transfer of land through a subdivision as defined herein shall be exempt from the provisions of this ordinance even though the instrument or document of transfer may describe land so subdivided by metes and bounds.
- D. The regulations within this ordinance are adopted under the authority of the constitution and laws of the State of Texas, including Chapter 42, Chapter 212, and Chapter 242 of the Texas Local Government Code. Pursuant to the authority herein granted, the City Council extends to all of the area within its City limits and extraterritorial jurisdiction (ETJ), the application of all of the terms and provisions in this ordinance establishing rules and regulations governing plats and subdivisions of land.

- E. The developer, property owner, or designated homeowner association shall be responsible for ongoing compliance with the provisions of this ordinance. Provisions of this ordinance unrelated to the subdivision of property shall be an ongoing obligation for applicable properties or developments.

Sec.1.3. Consistency with city master plan and transportation plan

This ordinance is intended to implement the policies and objectives contained in the City's Master Land Use Plan (Comprehensive Plan) and Transportation Plan for the City and provide for adequate and necessary public facilities and service.

Sec.1.4. Definitions

For the purposes of this ordinance, the following terms, phrases, words and their derivations shall have the meaning given in this section. When not inconsistent with the context, words used in the present tense include the future; words used in the singular number include the plural number; and words in the plural number include the singular number. The words "shall" and "will" are always mandatory, while the word "may" is merely discretionary. The words "may not" and "shall not" are both prohibitive.

Any term not expressly defined in this section shall be defined by a common planning definition from the American Planning Association's - A Planners Dictionary. The City Manager shall determine the appropriateness of a definition.

- Alley - A public right-of-way which provides a secondary means of vehicular access to abutting property and which is used primarily for vehicular traffic to the rear or side of properties which otherwise abut on a street.
- Alley, Commercial – An alley designed to access the rear or side of non-residential lots or the rear of residential lots with rear entry garages.
- Alley, Private – A private way which provides a secondary means of vehicular access to abutting property and which is used primarily for vehicular traffic to the rear or side of properties which otherwise abut on a street.
- Alley, Residential – An alley designed to access the rear or side of residential lots without rear entry garages.
- Block: A tract of land bounded by streets or a combination of streets and public parks, or corporate boundaries of the City.
- City: The City of Garden Ridge, Texas
- City Manager: The City Manager of the City of Garden Ridge, Texas or his/her designee.
- City Council: The City Council of the City of Garden Ridge, Texas.
- City Engineer: A registered professional engineer employed or designated by the City to provide professional engineering services for and on behalf of the City.

- Cul-de-sac: A street having but one (1) outlet to another street, and terminated on the opposite end by a vehicular turn around.
- Dead End Street: A roadway, other than cul-de-sac, with only one (1) outlet.
- Dedicatory instrument: means each governing instrument covering the establishment, maintenance, and operation of a residential subdivision. The term includes restrictions or other similar instruments that subject property to restrictive covenants, bylaws, or similar instruments governing the administration or operation of a property owners' association; allow for properly adopted rules and regulations of the property owners' association; and authorize enactment of lawful amendments to the covenants, bylaws, rules, or regulations.
- Development: Any manmade change in improved and unimproved real estate, including but not limited to buildings or other structures, mining, dredging, filling, grading, paving, excavation or drilling operations or storage of equipment.
- Dwelling Unit: A single housing unit providing complete independent living facilities for one or more persons living as a single housekeeping unit, including permanent provisions for living, sleeping, eating, cooking and sanitation.
- Easement: An acquired privilege or right-of-way use which a person, business, entity and/or public agency has across, over or under land of another person, business, entity and/or public agency.
- Easement, Non-Access: An easement dedicated to the public prohibiting vehicular traffic on, over, or across said easement.
- Easement, Overhang: An interest in land granted to the City, to the public generally, and/or a utility for installing or maintaining utilities over private land. This easement does not grant the right of entry there on with machinery and vehicles for maintenance.
- Easement, Sidewalk: An interest in land granted to the public for the installation of a public use of a sidewalk across or over private land, together with the right to enter thereon with machinery and vehicles necessary for sidewalk installation and maintenance
- Easement, Utility: An interest in land granted to the City, to the public generally, and/or to a private utility, for installing or maintaining utilities across, over or under private land, together with the right to enter thereon with machinery and vehicles necessary for the maintenance of said utility.
- Floodplain: Any land area susceptible to being inundated by water from the unusual and rapid accumulation or runoff of surface waters from any source.
- Floodway: The channel of a river or other watercourse and portions of the adjacent land areas that must be reserved in order to discharge the base flood without cumulatively increasing the water surface elevation more than a designated height as shown on a current Flood Insurance Rate Map (FIRM) provided to the City of Garden Ridge by Federal Emergency Management Agency (FEMA) or as determined by an engineering study in areas not depicted in the current floodway map.
- Half-Street: Any portion of a street which does not meet the minimum right-of-way widths or pavement widths required by this ordinance or which is to be widened to full width at some later date.
- Landscape island: A landscaped area within a roadway or private driveway, typically separating inbound and outbound traffic flows.
- Lot: An undivided tract or parcel of land having frontage on a public or private street or other approved access and which is, or in the future may be, offered for sale, conveyance, transfer or improvements;

which is designated as a distinct and separate tract; and/or, which is identified by a tract or lot number or symbol in a duly approved subdivision plat which has been properly recorded.

- Lot Area: The area of a lot bounded by lot lines, including any portion of an easement which may exist within such lot lines.
- Lot Frontage: That part of a lot (a lot line) abutting on a street or approved access way; except that the ends of incomplete streets or streets without a turnaround, shall not be considered frontage.
- Lot, Corner: A lot which has an interior angle of less than 135 degrees at the intersection of two (2) street lines. A lot abutting upon a curved street shall be considered a corner lot if the tangents of the curve at the points of the intersection of the side lot lines intersect at an interior angle of less than 135 degrees.
- Lot, Double Front: Any lot, not a corner lot, with frontage on two streets which are parallel to each other or within 45 degrees of being parallel to each other.
- Lot, Flag: A lot shaped and designed where the main building site area is set back substantially from the roadway and access is limited to a narrow private drive. Flag lot shapes are often used to achieve minimal lot frontage on the roadway.
- Lot, Interior: A building lot other than a corner lot.
- Median: The portion of a divided street or roadway that separates opposing lanes of traffic, often landscaped or paved, and may include curbs or barriers.
- Parkland: Land used for park and recreational purposes, typically dedicated to the public.
- Peak Hour Trips (PHT): The number of traffic units generated by and attracted to the proposed development during its heaviest hour of use, dependent on type of use.
- Permit: An official document or certificate issued by the authority having jurisdiction authorizing performance of a specified activity.
- Plat: The map, drawing or chart on which a subdivider's plan of a subdivision is presented and submitted for approval.
- Property owners' association: means an incorporated non-profit association that meets the definition of a Property Owner's Association in Section 204.004 with Texas Property Code and manages or regulates the residential subdivision for the benefit of the owners of property in the subdivision.
- Public Infrastructure: Infrastructure that is generally for public use to include but not be limited to improvements of the following: water system (including water distribution lines, fire hydrants, valves and associated devices), wastewater (including lines, manholes, and lift stations), drainage system (including drainage easements, channels, storm sewer lines and inlets and associated landscaping), sidewalks, and roadways.
- Regular assessment: means an assessment, a charge, a fee, or dues that each owner of property within a residential subdivision is required to pay to the property owners' association on a regular basis and that is designated for use by the property owners' association for the benefit of the residential subdivision as provided by the dedicatory instrument.
- Right-of-Way: The right of passage acquired for or by the public through dedication, purchase or condemnation and intended to provide pedestrian and vehicular access to abutting lots, tracts or areas which may also be used for utilities and to provide for drainage ways.

- Road: See the definition of "Street".
- Special assessment: means an assessment, a charge, a fee, or dues, other than a regular assessment, that each owner of property within a residential subdivision is required to pay to the property owners' association, according to the procedures required by the dedicatory instrument, for:
 - Defraying, in whole or part, the cost whether incurred before or after the assessment, of any construction or reconstruction, unexpected repair, or replacement of a capital improvement in common areas owned by the property owners' association, including the necessary fixtures and personal property related to the common areas;
 - Maintenance and improvement of common areas owned by the property owners' association; or
 - Other purposes of the property owners' association as stated in its articles of incorporation or the dedicatory instrument for the residential subdivision.
- Street: A strip of land comprising the entire rights-of-way intended for use as a means of vehicular and pedestrian circulation to provide access to more than one (1) lot.
- Street, Arterial: A limited access street designed to carry a large volume of traffic from one part of the city to another, along a route generally indicated in the city's comprehensive plan.
- Street, Collector: A street which collects traffic from two or more local streets and feeds into another collector or an arterial street.
- Street, Interior: A street which enters or traverses a subdivision, or whose entire course is located within the boundaries of a subdivision, as distinguished from a perimeter street.
- Street, Limited Access: A street along which direct vehicular ingress and egress to and from adjacent residential property is prohibited.
- Street, Marginal : A street which is parallel and adjacent to a limited access street or collector street and which primarily provides vehicular access to abutting properties and protection from high speed through traffic.
- Street, Local: Any street other than an arterial, a collector street, or a marginal access street, which serves and is accessed by individual properties and lots fronting thereon.
- Street, Perimeter: A street or dedicated street right-of-way adjacent to and abutting the boundary of any subdivision or tract of land.
- Street, Private: Any street right-of-way not dedicated to public use.
- Street, Public: Any roadway for use of vehicular traffic dedicated to public use and/or owned, controlled and maintained by the City, a County, or the State.
- Subdivider or Developer: Are synonymous and include any person, partnership, firm, association, corporation (or combination thereof), or any officer, agent, employee, servant, or trustee thereof, who performs, or participates in the performance of, any act toward the subdivision of land within the intent, scope and purview of this ordinance.
- Subdivision: The division of any lot, tract or parcel of land into two (2) or more lots, tracts or parcels of land for the purpose, whether immediate or future, of sale or development, situated within the City's corporate limits or extraterritorial jurisdiction (ETJ). It also includes vacation and resubdivision of land or lots.

- Surveyor: A State licensed land surveyor or registered public surveyor, as authorized by the state statutes, to practice the profession of surveying.
- Utility Easement: An interest in land granted to the City, to the public generally, and/or to a private utility corporation, for installing utilities and appurtenances across, on, over, upon or under private land, together with the right to enter thereon with machinery and vehicles necessary for the maintenance of said utilities.
- Visibility Triangle: The triangular sight area from the corner of converging streets extending 25 feet along each right-of-way with the triangle completed by drawing a line through the property from both 25 foot points on the converging streets.

DRAFT

Sec.1.5. Public facilities required

- A. The subdivider is responsible for all costs associated with furnishing, installing, and constructing public facilities (including but not limited to, water and wastewater systems, streets, sidewalks, trails, and drainage facilities) necessary for the proper development of the subdivision according to the minimum standards adopted by the City.
- B. All required public facilities must be designed and constructed in accordance with the City's adopted technical manuals, and any other standards, specifications, and drawings the City may adopt. If the City does not have jurisdiction over a facility, the subdivider must design the facility according to the specifications of the provider.

Sec.1.6. Rough proportionality and fair share

- A. If the City requires as a condition of approval for a property development project that the property owner bear a portion of the costs of municipal infrastructure improvements through dedication of property to the City, the payment of impact fees, the payment of construction costs, or the payment of other infrastructure related costs authorized by applicable law, the property owner's portion of the costs may not generally exceed the amount required for infrastructure improvements that are roughly proportionate to the proposed development as approved by the City Engineer.
- B. A property owner who disputes the determination made by the City Engineer under Subsection A above must appeal to the City Council within 30 days of the determination, or the City Engineer's determination is final. At the appeal, the property owner may present evidence and testimony under procedures adopted by the City Council. After hearing any testimony and reviewing the evidence, the City Council shall make the applicable determination as to the appeal within thirty (30) calendar days after the final submission of any testimony or evidence by the property owner.
- C. A property owner may appeal the determination of the City Council to a county or district court of the county in which the development is located within thirty (30) calendar days after the final determination by the City Council.

Sec.1.7. Vested rights

- A. Introduction. LGC Chapter 245 - Issuance of Local Permits, commonly referred to as the State's "Vested Rights Law", provides an opportunity for landowners or developers to "grandfather" or "vest" government regulations that apply to development at the time of the filing of a permit application. The City has established in this section an administrative procedure for consideration of any claim of a vested right.
- B. Definitions. The following terms shall have the meaning hereinafter ascribed to them under this section:

LGC – The Texas Local Government Code

Project – an endeavor over which the City (a regulatory agency, as defined by LGC Chapter 245) exerts its jurisdiction and for which one or more permits are required to initiate, continue, or complete the endeavor.

Permit - a license, certificate, approval, registration, consent, permit, contract, or other agreement for construction related to, or provisions of, service from a water or wastewater utility owned, operated, or controlled by the City, or other form of authorization required by law, rule, regulation, order or ordinance that a person must obtain to perform an action or initiate, continue, or complete a Project for which the permit is sought (i.e. subdivision master plan, preliminary plat or final plat).

- C. Administrative procedure for consideration of claim of vested rights. Any property owner claiming vested rights under Chapter 245 of the LGC, or other applicable vesting law, shall submit a letter explaining in sufficient detail the basis upon which the property owner is claiming vesting and, consequently, is exempt from or not subject to a particular current regulation, ordinance, rule, expiration date, or other requirement. Such written submission shall include, at a minimum, the following:
 - 1. The name, mailing address, and telephone number of the property owner (or the property owner's duly authorized agent);
 - 2. Identification of the property, including the address (if it exists) and the plat reference (if it exists) or metes and bounds description (if not platted), for which the property owner claims a vested right;
 - 3. Project name, type of permit and date the permit was filed;
 - 4. All particular regulations which the applicant is claiming do not apply to the project; and
 - 5. Attach all supporting documents, if any.
- D. Vested rights determination. The City Manager will review the request and supporting documents and issue a final administrative determination of whether a vested right exists in relation to the project and shall identify in writing to the property owner, or designated agent, all claims for which vested rights have been granted (the "Vested Rights Determination").
- E. Appeal of Vested Rights Determination. If the property owner believes that the Vested Rights Determination is in error, the property owner shall have the right to appeal such Vested Rights Determination within 30 days of the determination to the City Council, which will have jurisdiction to hear and decide the appeal pursuant to this ordinance and LGC Chapter 245.
- F. Permits, Projects, and Vested Rights.
 - 1. A property owner's original permit application expires on or after the forty-fifth (45th) calendar day after the date the application is filed if:
 - a. the property owner fails to provide documents or other information necessary to comply with the City's technical requirements relating to the form and content of the permit application;
 - b. the City provides to the property owner, not later than the tenth (10th) business day after the date the application is filed, written notice of the failure that specifies the necessary documents or other information and the date the application will expire if the documents or other information is not provided; and
 - c. the property owner fails to provide the specified documents or other information within the time provided in the written notice.
 - 2. Permits and Projects Expiration.

- a. Only a project which was in progress (as defined by LGC Section 245.003) or for which a permit application was filed after September 1, 1997 may be eligible to claim vested rights; any project for which the permit application was filed prior September 1, 1997, or has expired, is not eligible. Vested rights do not begin to accrue until the filing of an original application or subdivision master plan or plat application that gives the City fair notice of the project to which the permit applies and the nature of the permit sought.
- b. A project will expire in five (5) years from the date the first permit application was filed for the project with City if progress, as defined in LGC Section 245.005, has not been made towards completion of the project. An expired project is considered dormant, vested rights lapse, and the project must comply with all current ordinances and requirements.
- c. The following Permits (as well as other Permits satisfying the requirements of LGC Chapter 245), which include Plat Applications and Plats, may be relied on by a property owner or developer to establish certain vested rights for a Project unless otherwise exempted by LGC Section 245.004 or its successor statute. A Project will expire in five (5) years from the date the first Permit application was filed for the Project with the City if progress, as defined in LGC Section 245.005 or its successor statute, has not been made towards completion of the Project. An expired Project is considered dormant, vested rights lapse, and the Project must comply with current ordinances and requirements.
 - i. Plat Applications. Vested rights under LGC Chapter 245 will be recognized for the Project that is the subject of a completed application for a plat that has been filed with the City, provided all necessary fees have been paid.
 - ii. Plats. Vested rights under LGC Chapter 245 will be recognized for a Project associated with the property which is the subject of a plat that has been approved by the City Council or Official for the City provided that fair notice is provided with the plat application in accordance with LGC Chapter 245.
 - iii. Other Permits. For the purposes of determining whether any vested rights exist, any other Permit for which an expiration date is not specifically set forth in this Code of Ordinances or in other applicable law shall expire two (2) years after the date the application for the Permit was filed with the City if progress, as defined in LGC Section 245.005, has not been made towards completion of the Project.

Sec.1.8. Unauthorized subdivisions or developments

- A. Unauthorized subdivisions.
 - 1. It shall be unlawful for any landowner, or the agent of any landowner to lay out, subdivide, plat, or replat any land into lots, blocks and streets within the jurisdictional limits of the City without the approval of the City in accordance with this ordinance.
- B. Permits in unauthorized subdivisions.
 - 1. No building permit or permit for the construction of a structure, with the exception of accessory structures, shall be issued by the City for any structure on a lot in a subdivision until the final plat of the subdivision has been approved and filed for record with the County and the subdivision has been accepted by the City, with the following exceptions:

- a. Permits for additions to existing structures not exceeding twenty-five percent (25%) of the building at the time of the adoption of this ordinance; and
 - b. Permits for interior finish out or improvements to existing structures; and
 - c. Permits for repair or maintenance.
- C. Public Services in unauthorized subdivisions.
- 1. The City shall not repair, maintain, install or provide any streets in any subdivision for which a plat has not been approved, where required, and filed for record with the County, or in which the standards contained herein or referred to herein have not been complied with in full.
- D. Utility services in unauthorized subdivisions.
- 1. No utility, including the City, shall sell any water, gas, electricity or sewage service, nor install a septic system, within a subdivision for which a plat has not been approved and filed for record with the County, or in which the standards contained herein or referred to herein have not been complied with in full.

Sec.1.9. Development manual

- A. The Development Manual shall contain development application forms, required application materials, fees, and application submittal deadlines. The Development Manual may be adopted and updated from time to time by Resolution approved by City Council. A copy of the current Development Manual shall be posted to the City's website. Any amendment to the Development Manual related to subdivision applications shall be published to the City's website within 30 calendar days from when the amendment is made in accordance with LGC Section 212.0081 or its successor statute.

Sec.1.10. Public works specification manual

- A. The Public Works Specification Manual shall contain specifications necessary to complete public projects including but not limited to roadway design specifications, traffic impact requirements, utility easement specifications, and driveway requirements. The Public Works Specification Manual may be adopted and updated from time to time by ordinance approved by the City Council. In accordance with LGC Sections 212.002 & 212.0021 or its successor statute, prior to adopting or amending the Public Works Specification Manual a public hearing is required and notice of the public hearing shall be published in a newspaper of general circulation in the city. A copy of the current Public Works Specification Manual shall be available upon request.

Sec.1.11. Interpretation and conflicts between regulations

- A. In the interpretation and application of the provisions of these regulations, it is the intention of the City Council that the principles, standards and requirements provided for herein shall be minimum requirements for the platting and developing of subdivisions in the city, and where other ordinances of the city are more restrictive in their requirements, such other ordinances shall control. The interpretation and application of the provisions of these regulations shall be held to be the minimum requirements for the promotion of public health, safety, and general welfare.

- B. In the event of a conflict between the requirements of this ordinance and State law, the requirements of State law shall apply.
- C. In the event of a conflict between the regulations contained within this ordinance and regulations or standards contained within any other ordinance, code or regulation of the City, the more restrictive regulation shall apply.
- D. In the event of a conflict between the regulations contained within this ordinance and the City's Development Manual or Public Works Specification Manual, the requirements of this ordinance shall apply.

Sec.1.12. Violations and penalties

- A. Any person, firm, or corporation who shall violate any of the provisions of this ordinance, or fails to comply therewith, or who shall violate or fail to comply with any order or regulation made hereunder, or who shall build any project or facility in violation of any detailed statement of specification or plans submitted and approved hereunder, or any certificate or permit issued hereunder, shall, for each and every violation and noncompliance respectively be deemed guilty of a misdemeanor and upon conviction thereof shall be fined a sum not to exceed two thousand dollars (\$2,000) or the appropriate legal maximum as determined by statute. Each and every day that such violation and/or noncompliance shall exist shall be deemed a separate offense. In case any person, firm, or corporation violates any of the provisions of this ordinance or fails to comply therewith, the City, in addition to imposing the penalties above provided may institute any appropriate action or proceedings in court to prevent, restrain, correct, or abate or to prevent any illegal act, conduct, business, or use in or about any land, and the definition of any violation of the terms of this ordinance as a misdemeanor, shall not preclude the City from invoking the civil remedies given it by law in such cases, but same shall be cumulative of and in addition to the penalties prescribed for such violation.

Sec.1.13. Validity

- A. The issuance or granting in error of a permit or approval of plans or plats, site designs, or specifications shall not be construed to be a permit for, or an approval of, a violation of any provision of this ordinance or any other City ordinance.

Section 2. Procedures

Sec.2.1. General

- A. The purpose of this section is to establish application procedures, internal review procedures, public notice and hearing procedures, and review criteria for the processing of applications and actions that affect the development and use of property subject to the jurisdiction of the City of Garden Ridge.

- B. The owner of a tract of land located within the City limits or extraterritorial jurisdiction (ETJ) who divides the tract in two (2) or more parts to lay out a subdivision of the tract, including an addition to the City, to lay out suburban, building, or other lots, or to lay out streets, alleys, squares, parks, or other parts of the tract intended by the owner of the tract to be dedicated to public use must have a plat of the subdivision prepared. A division of a tract under this section includes a division regardless of whether it is made by using a metes and bounds description in a deed of conveyance or in a contract for a deed, by using a contract of sale or other executory contract to convey, or by using any other method. In accordance with Texas Local Government Code Chapter 212, subdivisions of land in which each tract is greater than five (5) acres, where each tract has access, and no public improvement is being dedicated, are not required to plat to divide the land.

Sec.2.2. Initiation of application

- A. Application submittal. All development applications to be considered by any Board, Commission or Committee, or by the City Council shall be initiated by the filing of the application by the owner of the property on which the permit is applicable or by the owner's designated agent. In the event an application is submitted by a designated agent, the application must be accompanied by a written statement, signed by the owner, authorizing the agent to file the application on the owner's behalf.
- B. Determination of application completeness.
 - 1. All submitted development applications shall be subject to a determination of completeness by the City Manager or their designee.
 - 2. No application shall be deemed complete and accepted for filing unless it is accompanied by all documents required by and prepared in accordance with the requirements of the City and any required fees have been paid.
 - 3. A determination of completeness shall not constitute a determination of compliance with the substantive requirements of this ordinance.
 - 4. Not later than the tenth (10th) business day after the date an application is submitted, the City Manager shall make a written determination whether the application constitutes a complete application. This shall include a determination that all information and documents required by the City for the type of plan/plat/permit being requested have been submitted. A determination that the application is incomplete shall be sent to the applicant within such time period by email to the address listed on the application or by United States mail at the address listed on the application with the date the application was submitted. The determination shall specify the documents or other information needed to complete the application. Applications considered incomplete shall not be deemed filed with the city and shall be made available to the applicant for pick up at City Hall. All incomplete applications not picked up within 10 business days may be discarded at the discretion of the City Manager. If an application is considered incomplete, a new application package must be submitted.
 - 5. Applications which are determined to be complete shall be considered filed on the date the complete application was received by the City.
 - 6. The processing of an application by any City employee other than the City Manager prior to the time the application is officially determined to be complete shall not be binding on the City as the official acceptance of the application.

7. No vested rights accrue solely from the submission of an incomplete application that has expired pursuant to this section.
- C. Application withdrawal. Any request for withdrawal of an application must be submitted in writing to the City Manager. If notification is required for the application and has been properly given via publication in the newspaper and/or written notification to surrounding property owners, such application must be placed on the agenda. The staff representative shall notify the Board, Commission, Committee or the City Council of the request for withdrawal. Application fees are not refundable unless reimbursement is otherwise authorized by the City Manager.

Sec.2.3. Pre-application conference

- A. Prior to submitting an application for approval of a development, subdivision master plan, or subdivision plat, the subdivider, at his/her option, may consult with and present a proposed plan for the subdivision to the City Manager or his/her designee for comments and advice on the procedures, specifications, and standards required by the City for the subdivision of land. At such a meeting the city staff will be able to make any suggestions that would direct the proposed subdivision toward desirable objectives and possibly prevent unnecessary work and expense if objectives are not met. No vesting shall occur under this section in accordance with this ordinance.

Sec.2.4. Certification of exhibits

- A. Applicability. Prior to filing an application for a subdivision master plan or subdivision plat approval the applicant shall secure letters of certification as required by this ordinance and the Development Manual. A request for a letter of certification and required items shall be submitted by the applicant as required by the Development Manual.
- B. Application requirements. Any request for a letter of certification shall be accompanied by an application prepared in accordance with the City's Development Manual.
- C. Processing of application and decision.
 1. Submittal. A request for a letter of certification shall be submitted to the City Manager. The City Manager shall review the application for completeness. The City Manager may request a review and recommendation from any other City department or consultant.
 2. Decision by the City Manager.
 - a. After the City Manager has determined whether the request for letters of certification and required technical data is complete, the City Manager shall issue comments, approve or deny a letter of certification within forty-five (45) calendar days. When the City Manager determines that the proposed plan, plat or any of the required accompanying data does not conform with the requirements of this ordinance or other applicable regulations, ordinances or laws, the applicant may at his/her option revise any nonconforming aspects. If any data is revised and resubmitted, the City Manager shall have up to thirty (30) calendar days from the latest date of submission to issue comments, approve or deny a letter of certification.

- b. If a letter of certification is not issued, denied, or review comments issued within the time periods prescribed in subsection above, the same shall be deemed issued and the applicant may submit an application for subdivision master plan or subdivision plat, without submitting the letter of certification.
3. Scope of issuance. A letter of certification does not authorize the development or subdivision of land. Upon receipt of all required letters of certification, the applicant may submit an application for subdivision master plan or subdivision plat approval. Letters of certification shall remain valid for one (1) year from the date of issuance by the certifying department. After that time period, new or updated letters of certification shall be required to file a subdivision master plan or subdivision plat application.
4. Amendments. A letter of certification may be amended prior to filing an application for subdivision approval if the proposed amendment:
 - a. Does not increase the number of lots subject to the application.
 - b. Does not increase by more than five percent (5%) the lineal footage of roadways or the areas within the paved surface of the street right-of-way.
 - c. Does not reduce the amount of open space within the proposed subdivision.
 - d. Does not alter or change the approved stormwater plan.
5. Letter of certification authorization. A letter of certification is not recorded. A letter of certification shall be maintained by the applicant and presented with the application for subdivision master plan or subdivision plat approval.

Sec.2.5. Subdivision master plan

- A. Applicability.
 1. A subdivision master plan is required to provide for review of certain developments for compliance with, this ordinance, any additional adopted plans (i.e. water, wastewater, transportation, drainage), the compatibility of land uses, and the coordination of improvements within and among individual parcels of land or phases of development prior to approval of a preliminary or final plat. A subdivision master plan is required for any development meeting one or more following criteria:
 - a. The proposed subdivision of land is to occur in phases; or
 - b. The proposed subdivision is creating more than four (4) lots; or
 - c. The property is undeveloped and is greater than ten (10) acres in size.
 2. If a preliminary plat encompasses the entire development and tract of land, a subdivision master plan will not be required.
- B. Application requirements. Any request for a subdivision master plan shall be accompanied by an application prepared in accordance with the City's Development Manual.
- C. Processing of application and decision.

1. Submittal. An application for a subdivision master plan shall be submitted to the City Manager. The City Manager shall review the application for completeness. The City Manager may request a review and recommendation from any other city department or consultant. After appropriate review, the City Manager shall forward a written recommendation to the City Council for consideration.
 2. Decision by City Council. The City Council shall receive the written recommendation of the City Manager and shall consider the proposed subdivision master plan. The City Council shall act on the plan within thirty (30) calendar days after the date a complete application is filed, unless the applicant requests, in writing, an extension for a period not to exceed thirty (30) days and the City Council approves the extension request. The City Council must approve a subdivision master plan that is required to be prepared in accordance with this section and that satisfies all applicable regulations of the City. The City Council may vote to approve with conditions or deny a subdivision master plan that does not satisfy all applicable regulations of the City.
 3. Conditional approval and denial. If the City Council conditionally approves or denies the subdivision master plan, a written statement must be provided to the applicant clearly articulating each specific condition for the conditional approval or reason for denial. Each condition or reason specified in the written statement may not be arbitrary and must include a citation to the regulation, ordinance, or law that is the basis for the conditional approval or denial.
 4. Applicant response to conditional approval or denial. After the conditional approval or denial of a subdivision master plan, the applicant may submit a written response that satisfies each condition for the conditional approval or remedies each reason for denial provided. The City Manager is authorized to approve revisions required for conditional approval of the subdivision master plan. The City Manager may, for any reason, elect to present the master plan for approval to the City Council. The City Council shall determine whether to approve or deny the applicant's previously denied subdivision master plan or conditionally approved, if forwarded to the City Council by the City Manager. Action shall be taken by the City Manager or City Council no later than the fifteenth (15th) calendar day after the date the response was submitted.
 5. Subdivision master plan authorization. Approval of a subdivision master plan by the City Council shall be deemed as an expression of the approval of the layout submitted on the master plan as a guide to the final design of streets, water, sewer and other required improvements and utilities and to the preparation of a preliminary plat in accordance with the requirements of the City.
- D. Criteria for approval. The City Council, in considering final action on a subdivision master plan, should consider the following criteria:
1. The subdivision master plan is consistent with all city requirements including zoning requirements for the property or any development regulations approved as part of a development agreement;
 2. The proposed provision and configuration of roads, water, wastewater, drainage and park facilities are adequate to serve each phase of the subdivision;
 3. The schedule of development is feasible and prudent and assures that the proposed development will progress to completion within the time limits proposed;

4. The location, size and sequence of the phases of development proposed assures orderly and efficient development of the land subject to the plan; and
 5. All outstanding application and review fees have been paid.
- E. Expiration. The approval of a subdivision master plan shall remain in effect for a period of two (2) years after the date the application was approved or conditionally approved, during which period the applicant shall submit and receive approval for a preliminary plat for any portion of the land subject to the subdivision master plan. If a preliminary plat has not been approved within the two (2) year period, the subdivision master plan approval shall expire and the plan shall be null and void.
- F. Revisions to an approved subdivision master plan.
1. Minor changes. Minor changes in the design of the subdivision subject to a subdivision master plan may be incorporated in an application for approval of a preliminary plat without the necessity of filing a new application for approval of a subdivision master plan. Minor changes shall include adjustment in street or alley alignments, lengths, and adjustment of lot lines that do not result in creation of additional lots, provided that such changes are consistent with any approved prior applications.
 2. Major Changes. All other proposed changes to the design of the subdivision subject to an approved subdivision master plan, including but not limited to addition or removal of streets, change in the number of lots, or substantial change in lot sizes or configurations, shall be deemed major amendments that require submittal and approval of a new application for approval of a revised subdivision master plan before approval of a preliminary plat.

Sec.2.6. Preliminary plat

- A. Applicability.
1. A preliminary plat is required to determine the general layout of the subdivision, the adequacy of public facilities needed to serve the intended development and the overall compliance of the land division with applicable City requirements.
 2. A preliminary plat may be submitted for any phase of development consistent with an approved subdivision master plan. Where a subdivision master plan is not required and the area to be platted is part of a larger tract of land, the preliminary plat must encompass the entire tract of land under ownership of the subdivider and shall provide a preliminary layout of streets, lots, blocks, utilities and drainage for the larger tract. A final plat may be submitted for individual lots to be platted out of the larger parcel.
- B. Application requirements. Any request for a preliminary plat shall be accompanied by an application prepared in accordance with the City's Development Manual.
- C. Processing of application and decision.
1. Submittal. An application for a preliminary plat shall be submitted to the City Manager. The City Manager shall review the application for completeness. The City Manager may request a review and recommendation from any other city department or consultant. After appropriate review, the City Manager shall forward a written recommendation to the City Council for consideration.

2. Decision by City Council. The City Council shall receive the written recommendation of the City Manager and shall consider the proposed plat. The City Council shall act on the plat within thirty (30) calendar days after the date a complete application is filed, unless the applicant requests, in writing, an extension for a period not to exceed thirty (30) days and the City Council approves the extension request. The City Council must approve a preliminary plat that is required to be prepared in accordance with this section and that satisfies all applicable regulations of the City. The City Council may vote to approve with conditions or deny a preliminary plat that does not satisfy all applicable regulations of the City.
 3. Conditional approval and denial. If the City Council conditionally approves or denies the plat, a written statement must be provided to the applicant clearly articulating each specific condition for the conditional approval or reason for denial. Each condition or reason specified in the written statement may not be arbitrary and must include a citation to the regulation, ordinance, or law that is the basis for the conditional approval or denial.
 4. Applicant response to conditional approval or denial. After the conditional approval or denial of a plat, the applicant may submit a written response that satisfies each condition for the conditional approval or remedies each reason for denial provided. The City Manager is authorized to approve revisions required for conditional approval of the preliminary plat. The City Manager may, for any reason, elect to present the plat for approval to the City Council. The City Council shall determine whether to approve or deny the applicant's previously conditionally approved or denied plat, if forwarded to the City Council by the City Manager. Action shall be taken by the City Manager or City Council no later than the fifteenth (15th) calendar day after the date the response was submitted.
 5. Preliminary plat authorization. Approval of a preliminary plat shall be deemed as an expression of the approval of the layout submitted on the plat as a guide to the final design of streets, water, sewer and other required improvements and utilities and to the preparation of a final plat in accordance with the requirements of this ordinance.
- D. Criteria for approval. The City Council, in considering final action on a preliminary plat, should consider the following criteria:
1. The plat is consistent with all city requirements including zoning requirements for the property;
 2. The plat conforms to the general layout of the subdivision master plan (if applicable) and is consistent with the phasing plan approved therein;
 3. The proposed provision and configuration of roads, water, wastewater, drainage and park facilities, and easements and rights-of-way are adequate to serve the subdivision; and
 4. All outstanding application and review fees have been paid.
- E. Expiration and extension.
1. Expiration. The approval of a preliminary plat shall remain in effect for a period of two (2) years after the date the application was approved or conditionally approved, during which period the applicant shall submit and receive approval for a final plat for any portion of the land subject to the preliminary plat. If a final plat has not been approved within the two (2) year period, the preliminary plat approval, unless extended, shall expire and the plat shall be null and void.

2. Extension. At the request of the property owners or their representative, the expiration date for approval of a preliminary plat may be extended by the City Council for a period not to exceed six (6) months. A preliminary plat is not subject to reinstatement following expiration.
- F. Revisions to an approved preliminary plat.
1. Minor changes. Minor changes in the design of the subdivision subject to a preliminary plat may be incorporated in an application for approval of a final plat without the necessity of filing a new application for approval of a preliminary plat, subject to the approval of the City Manager. Minor changes shall include a revision to plat notes, a revision to street or alley lengths, scrivener's errors, adjustment of lot lines that do not result in the increase or creation of additional lots or additional acreage, or changes or clarifications to easements, provided that such changes are consistent with any approved prior applications.
 2. Major Changes. All other proposed changes to the design of the subdivision shall be deemed major changes which includes but is not limited to the reconfiguration of street or alley alignments, the addition of streets or alleys, an increase in the number of lots or acreage, the addition or revision of a unit previously approved by the preliminary plat, any change to the open space dedication requirement, changes to drainage. The City Manager shall determine if a change is minor or major. Major changes shall require submittal of a revised subdivision master plan (if applicable) and preliminary plat which is submitted and processed the same as a new subdivision master plan application and new preliminary plat application.

Sec.2.7. Final plat

- A. Applicability.
1. A final plat is required to assure that the division or development of the land subject to the plat is consistent with all standards of this ordinance pertaining to the adequacy of public facilities, that public improvements to serve the subdivision or development have been installed and accepted by the City or that provision for such installation has been made, that all other requirements and conditions have been satisfied or provided for to allow the plat to be recorded, and to assure that the subdivision or development meets all other standards of this ordinance to enable initiation of site preparation activities for any lot or tract subject to the plat. Approval of a final plat shall be required prior to any non-exempt division of land and prior to any site preparation activities for a lot or tract of land that requires installation of public improvements on or adjacent thereto.
 2. A final plat may be submitted for any phase of development consistent with an approved preliminary plat.
- B. Application requirements. Any request for a final plat shall be accompanied by an application prepared in accordance with the City's Development Manual.
- C. Processing of application and decision.
1. Submittal. An application for a final plat shall be submitted to the City Manager. The City Manager shall review the application for completeness. The City Manager may request a review and recommendation from any other city department or consultant. After appropriate review, the City Manager shall forward a written recommendation to the City Council for consideration.

2. Decision by City Council. The City Council shall receive the written recommendation of the City Manager and shall consider the proposed final plat. The City Council shall act on the plat within thirty (30) calendar days after the date a complete application is filed, unless the applicant requests, in writing, an extension for a period not to exceed thirty (30) days and the City Council approves the extension request. The City Council must approve a final plat that is required to be prepared in accordance with this section and that satisfies all applicable regulations of the City. The City Council may vote to approve with conditions or deny a final plat that does not satisfy all applicable regulations of the City.
 3. Conditional approval and denial. If the City Council conditionally approves or denies the final plat, a written statement must be provided to the applicant clearly articulating each specific condition for the conditional approval or reason for denial. Each condition or reason specified in the written statement may not be arbitrary and must include a citation to the regulation, ordinance, or law that is the basis for the conditional approval or denial.
 4. Applicant response to conditional approval or denial. After the conditional approval or denial of a plat, the applicant may submit a written response that satisfies each condition for the conditional approval or remedies each reason for denial provided. The City Manager is authorized to approve revisions required for conditional approval of the final plat. The City Manager may, for any reason, elect to present the plat for approval to the City Council. The City Council shall determine whether to approve or deny the applicant's previously conditionally approved or denied plat, if forwarded to the City Council by the City Manager. Action shall be taken by the City Manager or City Council no later than the fifteenth (15th) calendar day after the date the response was submitted.
- D. Criteria for approval. The City Council, in considering final action on a final plat, should consider the following criteria:
1. The plat is consistent with all city requirements including zoning requirements for the property;
 2. The final plat conforms to the approved preliminary plat, except for minor changes that may be approved without the necessity of revising the approved preliminary plat;
 3. The proposed provision and configuration of roads, water, wastewater, drainage and park facilities, and easements and rights-of-way are adequate to serve the subdivision; and
 4. All outstanding application and review fees have been paid.
- E. Expiration and extension.
1. Expiration. The approval of a final plat shall remain in effect for a period of two (2) years after the date the application was approved or conditionally approved, during which period the applicant shall submit any required revisions for approval and recordation of the plat. If the final plat has not been recorded within the two (2) year period, the final plat approval, unless extended, shall expire and the plat shall be null and void.
 2. Extension. At the request of the property owner or their representative, the expiration date for approval of a final plat may be extended by the City Council for a period not to exceed six (6) months. A final plat is not subject to reinstatement following expiration.
- F. Revisions following approval of final plat.

1. **Minor Changes.** An applicant may make minor changes to an approved final plat to reflect changes arising from installation of public improvements thereafter, provided that the approved final plat has not been recorded and that approval of the revised final plat occurs prior to expiration of approval of the initial final plat application. The City Manager is authorized to approve minor changes to an approved final plat. If the approved final plat has been recorded, an amending plat or replat must be approved and recorded. Minor changes shall include a revision to plat notes, a revision to street or alley lengths, scrivener's errors, adjustment of lot lines that do not result in the increase or creation of additional lots or additional acreage, or changes or clarifications to easements, provided that such changes are consistent with any approved prior applications.
2. **Major Changes.** All other proposed changes shall be deemed major changes which includes but is not limited to the reconfiguration of street or alley alignments, the addition of streets or alleys, an increase in the number of lots or acreage, the addition or revision of a unit previously approved by the preliminary plat, any change to the open space dedication requirement, changes to drainage. The City Manager shall determine if a change is minor or major. Major changes shall require submittal of a revised final plat which is submitted and processed the same as a new final plat application. Major changes may also require the submittal of a new application for approval of a preliminary plat before approval of a revised final plat.

Sec.2.8. Minor plat

- A. **Applicability.** A minor plat may be submitted for approval where the proposed division of land involves four (4) or fewer lots fronting onto an existing street and not requiring the creation of any new street or the extension of municipal facilities.
- B. **Application Requirements.** Any request for a minor plat shall be accompanied by an application prepared in accordance with the City's Development Manual.
- C. **Processing of Application and Decision.**
 1. **Submittal.** An application for a minor plat shall be submitted to the City Manager. The City Manager shall review the application for completeness. The City Manager may request a review and recommendation from any other city department or consultant.
 2. **Minor plat approval.** The City Manager may approve, approve with conditions, or disapprove a minor plat. The City Manager may, for any reason, elect to present the plat for approval to the City Council. The City Manager or the City Council shall act on the plat within thirty (30) calendar days after the date a complete application is filed, unless the applicant requests, in writing, an extension for a period not to exceed thirty (30) days and the City Council approves the extension request.
 3. **Conditional Approval and Denial.** If the plat is conditionally approved or denied, a written statement must be provided to the applicant clearly articulating each specific condition for the conditional approval or reason for denial. Each condition or reason specified in the written statement may not be arbitrary and must include a citation to the regulation, ordinance, or law that is the basis for the conditional approval or denial.

4. Applicant Response to Conditional Approval or Denial. After the conditional approval or denial of a plat, the applicant may submit a written response that satisfies each condition for the conditional approval or remedies each reason for denial provided. The City Manager is authorized to approve, approve with conditions, or disapprove the revisions. The City Manager may, for any reason, elect to present the plat for approval to the City Council. Action shall be taken by the City Manager or City Council no later than the fifteenth (15th) calendar day after the date the response was submitted.
 5. Appeal to City Council: Any decision to conditionally approve or disapprove a plat made by the City Manager may be appealed to the City Council.
- D. Criteria for approval. The following criteria should be considered when taking action on a minor plat:
1. The plat is consistent with all city requirements including zoning requirements for the property;
 2. All lots to be created by the plat are already adequately served by all required public utilities and infrastructure;
 3. The plat does not require the extension of any municipal facilities to serve any lot within the subdivision; and
 4. All outstanding application and review fees have been paid.
- E. Expiration and extension.
1. Expiration. The approval of a minor plat shall remain in effect for a period of two (2) years after the date the application was approved or conditionally approved. If the minor plat has not been recorded within the two (2) year period, the plat approval, unless extended, shall expire and the plat shall be deemed null and void.
 2. Extension. At the request of the property owners or their representative, the expiration date for approval of a minor plat may be extended by the City Manager or City Council for a period not to exceed six (6) months. A minor plat is not subject to reinstatement following expiration.

Sec.2.9. Amending plat

- A. Applicability. An amending plat may be submitted for approval, and if approved and recorded is controlling over the preceding plat without vacation of that plat and without notice and hearing, if the amending plat is signed and acknowledged by all owners of the property being replatted and is solely for one (1) or more of the following purposes:
1. to correct an error in a course or distance shown on the preceding plat;
 2. to add a course or distance that was omitted on the preceding plat;
 3. to correct an error in a real property description shown on the preceding plat;
 4. to indicate monuments set after the death, disability, or retirement from practice of the engineer or surveyor responsible for setting monuments;
 5. to show the location or character of a monument which has been changed in location or character or that is shown incorrectly as to location or character on the preceding plat;

6. to correct any other type of scrivener or clerical error or omission previously approved by the municipal authority responsible for approving plats, including lot numbers, acreage, street names, and identification of adjacent recorded plats;
 7. to correct an error in courses and distances of lot lines between two (2) adjacent lots if:
 - a. both lot owners join in the application for amending the plat;
 - b. neither lot is abolished;
 - c. the amendment does not attempt to remove recorded covenants or restrictions; and
 - d. the amendment does not have a materially adverse effect on the property rights of the other owners in the plat;
 8. to relocate a lot line to eliminate an inadvertent encroachment of a building or other improvement on a lot line or easement;
 9. to relocate one or more lot lines between one or more adjacent lots if:
 - a. the owners of all those lots join in the application for amending the plat;
 - b. the amendment does not attempt to remove recorded covenants or restrictions; or
 - c. the amendment does not increase the number of lots;
 10. to make necessary changes to the preceding plat to create six (6) or fewer lots in the subdivision or a part of the subdivision covered by the preceding plat if:
 - a. the changes do not affect applicable zoning and other regulations of the municipality;
 - b. the changes do not attempt to amend or remove any covenants or restrictions; and
 - c. the area covered by the changes is located in an area that the City Council has approved, after a public hearing, as a residential improvement area;
 11. to replat one or more lots fronting on an existing street if:
 - a. the owners of all those lots join in the application for amending the plat;
 - b. the amendment does not attempt to remove recorded covenants or restrictions;
 - c. the amendment does not increase the number of lots; and
 - d. the amendment does not create or require the creation of a new street or make necessary the extension of municipal facilities.
- B. Application Requirements. Any request for an amending plat shall be accompanied by an application prepared in accordance with the City's Development Manual.
- C. Processing of Application and Decision.
1. Submittal. An application for an amending plat shall be submitted to the City Manager. The City Manager shall review the application for completeness. The City Manager may request a review and recommendation from any other city department or consultant.

2. Amending plat approval. The City Manager may approve, approve with conditions, or disapprove an amending plat. The City Manager may, for any reason, elect to present the plat for approval to the City Council. The City Manager or the City Council shall act on the plat within thirty (30) calendar days after the date a complete application is filed, unless the applicant requests, in writing, an extension for a period not to exceed thirty (30) days and the City Council approves the extension request.
 3. Conditional Approval and Denial. If the City Council conditionally approves or denies the plat, a written statement must be provided to the applicant clearly articulating each specific condition for the conditional approval or reason for denial. Each condition or reason specified in the written statement may not be arbitrary and must include a citation to the regulation, ordinance, or law that is the basis for the conditional approval or denial.
 4. Applicant Response to Conditional Approval or Denial. After the conditional approval or denial of a plat, the applicant may submit a written response that satisfies each condition for the conditional approval or remedies each reason for denial provided. The City Manager is authorized to approve, approve with conditions, or disapprove the revisions. The City Manager may, for any reason, elect to present the plat for approval to the City Council. The City Council shall determine whether to approve or deny the applicant's previously conditionally approved or denied plat, if forwarded to the City Council by the City Manager. Action shall be taken by the City Manager or City Council no later than the fifteenth (15th) calendar day after the date the response was submitted.
 5. Appeal to City Council. Any decision to conditionally approve or disapprove a plat made by the City Manager may be appealed to the City Council.
- D. Criteria for approval. The following criteria should be considered when taking action on an amending plat:
1. The plat is consistent with all city requirements including zoning requirements for the property;
 2. All lots to be created by the plat already are adequately served by all required public utilities and infrastructure;
 3. The plat does not require the extension of any municipal facilities to serve any lot within the subdivision; and
 4. All outstanding application and review fees have been paid.
- E. Expiration and extension.
1. Expiration. The approval of an amending plat shall remain in effect for a period of two (2) years after the date the application was approved or conditionally approved. If the amending plat has not been recorded within the two (2) year period, the plat approval, unless extended, shall expire and the plat shall be deemed null and void.
 2. Extension. At the request of the property owners or their representative, the expiration date for approval of an amending plat may be extended by the City Manager or City Council for a period not to exceed six (6) months. An amending plat is not subject to reinstatement following expiration.

Sec.2.10. Replat

- A. Applicability. A replat is any plat that complies with LGC sections 212.014, 212.0145, and 212.015, as amended, which is generally submitted to replat a subdivision or part of a subdivision without vacation of the original plat. Replatting a portion of a recorded lot is not permitted.
- B. Application requirements. Any request for a replat plat shall be accompanied by an application prepared in accordance with the City's Development Manual.
- C. Processing of application and decision.
 - 1. Submittal. An application for a replat shall be submitted to the City Manager. The City Manager shall review the application for completeness. The City Manager may request a review and recommendation from any other city department or consultant. After appropriate review, the City Manager shall forward a written recommendation to the City Council for consideration.
 - 2. Notification requirements for certain replats.
 - a. Applicability. An application for a replat which is also accompanied by a waiver or variance request requires a public hearing and notice if:
 - i. during the preceding five years, any of the area to be replatted was limited by an interim or permanent zoning classification to residential use for not more than two residential units per lot; or
 - ii. any lot in the preceding plat was limited by deed restrictions to residential use for not more than two residential units per lot.
 - b. Public hearing notice. Notice of the public hearing shall be given at least sixteen (16) calendar days before the date of the public hearing by:
 - i. Publication in an official newspaper or a newspaper of general circulation in the county in which the City is located; and
 - ii. Written notice with a copy of LGC Sec. 212.015(c) attached, mailed to the owners of lots that are in the original subdivision and that are within 200 feet of the lots to be replatted, as indicated on the most recently approved municipal tax roll or in the case of a subdivision within the extraterritorial jurisdiction, the most recently approved county tax roll of the property upon which the replat is requested.
 - c. Protests. For a legal protest, written instruments signed by the owners of at least 20 percent of the area of the lots or land immediately adjoining the area covered by the proposed replat and extending 200 feet from that area, but within the original subdivision, must be filed with the City Council, prior to the close of the public hearing. If the proposed replat is protested in accordance with this subsection, the proposed replat must receive, in order to be approved, the affirmative vote of at least three-fourths of the City Council members present.
 - i. In computing the percentage of land area for protest, the area of streets and alleys shall be included.

3. Decision by the City Council. The City Council shall receive the recommendation of the City Manager and shall consider the proposed replat. A public hearing shall be held if the proposed replat is accompanied by a waiver or variance request in accordance with LGC Sec. 212.015. The City Council shall act on the replat within thirty (30) calendar days after the date a complete application is filed, unless the applicant requests, in writing, an extension for a period not to exceed thirty (30) days and the City Council approves the extension request. The City Council must approve a replat that is required to be prepared in accordance with this section and that satisfies all applicable regulations of the City. The City Council may vote to approve with conditions or deny a replat that does not satisfy all applicable regulations of the City.
 4. Conditional Approval and Denial. If the City Council conditionally approves or denies the replat, a written statement must be provided to the applicant clearly articulating each specific condition for the conditional approval or reason for denial. Each condition or reason specified in the written statement may not be arbitrary and must include a citation to the regulation, ordinance, or law that is the basis for the conditional approval or denial.
 5. Applicant Response to Conditional Approval or Denial. After the conditional approval or denial of a replat, the applicant may submit a written response that satisfies each condition for the conditional approval or remedies each reason for denial provided. The City Manager is authorized to approve revisions required for conditional approval of the replat. The City Manager may, for any reason, elect to present the replat for approval to the City Council. The City Council shall determine whether to approve or deny the applicant's previously conditionally approved or denied replat, if forwarded to the City Council by the City Manager. Action shall be taken by the City Manager or City Council no later than the fifteenth (15th) calendar day after the date the response was submitted.
- D. Criteria for Approval. The City Council in considering final action on a replat should consider the following criteria:
1. The replat is consistent with all city requirements including zoning requirements for the property;
 2. The replat is signed and acknowledged by only the owners of the property being replatted;
 3. If required, a public hearing was held and parties in interest and citizens have had an opportunity to be heard; and
 4. If required the proposed provision and configuration of roads, water, wastewater, drainage and park facilities, and easements and rights-of-way are adequate to serve the subdivision.
 5. The replat does not attempt to amend or remove any covenants or restrictions;
 6. All outstanding application and review fees have been paid.
- E. Notification of approval for certain replats. If a proposed replat does not require a variance or exception, but meets the criteria in subsection C.2.a.i or ii above, the municipality shall, not later than the 15th calendar day after the date the replat is approved, provide written notice by mail of the approval of the replat to each owner of a lot in the original subdivision that is within 200 feet of the lots to be replatted according to the most recent municipality or county tax roll. This subsection does not apply to a proposed replat if the City Council holds a public hearing and gives notice of the hearing in the manner provided in Sec.2.10.C.2 above.
1. The notice of a replat approval must include:

- a. the zoning designation of the property after the replat; and
 - b. a telephone number and e-mail address an owner of a lot may use to contact the City about the replat.
- F. Expiration and extension.
1. Expiration. The approval of a replat shall remain in effect for a period of two (2) years after the date the application was approved or conditionally approved. If the replat has not been recorded within the two (2) year period, the plat approval, unless extended, shall expire and the plat shall be deemed null and void.
 2. Extension. At the request of the property owners or their representative, the expiration date for approval of a replat may be extended by the City Council for a period not to exceed six (6) months. A replat is not subject to reinstatement following expiration.

Sec.2.11. Reserved

Sec.2.12. Vacating a plat

- A. Applicability. The provisions of this section are authorized under LGC Chapter 212 and shall be applicable to all areas within the jurisdiction of the City.
- B. Application Requirements. Any request for vacating a plat shall be accompanied by an application prepared in accordance with the City's Development Manual.
- C. Processing of Application and Decision.
 1. Submittal. An application for vacating a plat shall be submitted to the City Manager. The City Manager shall review the application for completeness. The City Manager may request a review and recommendation from any other city department or consultant. After appropriate review, the City Manager shall forward a written recommendation to the City Council for consideration.
 2. Decision by the City Council. The City Council shall receive the recommendation of the City Manager and shall consider the proposed plat vacation. The City Council may vote to approve, approve with conditions or deny a request for vacating a plat.
- D. Criteria for approval. The City Council in considering action on vacating a plat should consider the following criteria:
 1. The vacating plat is consistent with all zoning requirements for the property, all other requirements of this ordinance that apply to the plat vacation, and any other applicable city requirements;
 2. The vacating plat is signed and acknowledged by all owners of lots in the original plat; and
 3. The vacating plat is consistent with all other state requirements pertaining to vacating a plat;
 4. All outstanding application and review fees have been paid.
- E. Effect of Vacation.
 1. Upon the execution and recording of the vacating instrument, the previous plat shall no longer be in effect.

2. Regardless of the City Council's action on the petition, the applicant will have no right to a refund of any monies, fees or charges paid to the City nor to the return of any property or consideration dedicated or delivered to the City except as may have previously been agreed to by the City Council.
3. The plat is vacated when a signed, acknowledged instrument declaring the plat vacated is approved and recorded in the manner prescribed for the original plat.
4. The City Council, at its discretion, shall have the right to retain all or specific portions of road right-of-way or easements shown on the plat being considered for vacation. However, the City Council shall consider a request for vacating a plat upon satisfactory conveyance of easements or right-of-way in a separate legal document using forms provided by the City Attorney's office.

Sec.2.13. Recordation

- A. Recording procedures. After approval of a final plat, minor plat, amending plat or replat and acceptance of any required public improvements or execution of a Subdivision Improvement Agreement pursuant to this ordinance, the applicant may submit all required items to the City to record the plat in the county in which the land is located. Upon receipt of the plat recording submittal and notification of acceptance of required public improvements or execution of a Subdivision Improvement Agreement, the City Manager shall procure the signature of the City Engineer and the Mayor or his/her designee on the plat and shall promptly cause the plat to be recorded. No plat will be received for recording until all back taxes owed to the City have been paid in full and a certified copy of a tax certificate from the applicable county tax office has been received for the subject property.

Sec.2.14. Plat waivers

- A. General. The City Council may authorize waivers from the provisions of this ordinance when, in its opinion, undue hardship will result from requiring strict compliance. In granting a waiver, the City Council shall prescribe only conditions that it deems necessary or desirable to the public interest. In making their findings, the City Council shall take into account the nature of the proposed use of the land involved and existing uses of land in the vicinity, the number of persons who will reside or work in the proposed subdivision, and the probable effect of such waivers upon traffic conditions and upon the public health, safety, convenience, and welfare in the vicinity.
- B. Timing. Plat waivers shall be submitted prior to filing a plat application. The City will not issue a letter of certification for any proposed subdivision plat exhibits requesting a plat waiver until the requested waiver has been approved.
- C. Application requirements. Any request for a plat waiver shall be accompanied by an application prepared in accordance with the City's Development Manual.
- D. Processing of application and decision.
 1. Submittal. An application for a plat waiver shall be submitted to the City Manager. The City Manager shall review the application for completeness. The City Manager may request a review and recommendation from any other city department or consultant. After appropriate review, the City Manager shall forward a written recommendation to the City Council for consideration.

2. Public Hearing Notice. An application for a plat waiver requires written notice of the public hearing mailed to each owner of real property within 200 feet, as indicated by the most recently approved municipal tax roll, at least 11 days prior to the public hearing and consideration by the City Council.
3. Decision by City Council. The City Council shall receive the written recommendation of the City Manager and shall hold a public hearing and consider the proposed plat waiver request. The City Council may vote to approve, approve with conditions, or deny the plat waiver request.
- E. Conditions. In approving a plat waiver, the City Council may prescribe appropriate conditions that it deems necessary or desirable to the public interest.
- F. Criteria for approval. The following criteria should be considered when taking action on a plat waiver:
 1. That the granting of the waiver will not be detrimental to the public health, safety, or welfare, or injurious to other property in the area; and
 2. The granting of the waiver is in in harmony with the general purpose and intent of this ordinance so that the public health, safety, and welfare may be secured and justice done; and
 3. The granting of the waiver is necessary for the preservation and enjoyment of a substantial property right; and
 4. There are special circumstances or conditions affecting the land involved or other constraints such that the strict application of the provisions of this ordinance would deprive the Subdivider of the reasonable use of the land; and
 5. The waiver request represents the minimum degree of variation, in the opinion of the City Council, of requirements necessary to meet the needs of the subdivider; and
 6. The waiver is to a provision of this ordinance; and
 7. That the granting of the waiver will not have the effect of preventing the orderly subdivision of other land in the area in accordance with the provisions of this ordinance.
- G. The findings of the City Council, together with the specified facts upon which such findings are based, shall be incorporated into the official minutes of the City Council meeting at which such waiver is approved.
- H. Expiration. Approved waivers shall expire 12 months after approval if a plat application has not been filed with the City. If a plat application is filed before the waiver expires, the approved waiver shall be incorporated into the plat application and follow the same expiration timelines as the associated plat application.

Sec.2.15. Public infrastructure construction plans

- A. Applicability. The provisions of this section apply to the review of construction plans for any public infrastructure improvements.
- B. Application Requirements. Any request for review of construction plans for any public infrastructure improvements shall be accompanied by an application prepared in accordance with the City's Development Manual and Public Works Specification Manual as applicable.

- C. Processing of Application and Decision.
 - 1. An application shall be submitted to the City Manager. The City Manager shall review the application for completeness. The City Manager may request a review and recommendation from any other city department or consultant.
 - 2. Decision by the City Manager. The City Manager may approve, approve with conditions or deny the construction plans.
- D. Criteria for Approval. The City Manager shall apply the following criteria in making a decision on the construction plans:
 - 1. The construction plans are consistent with the approved preliminary plat or the proposed final plat in the event that the public infrastructure improvements are in relation to a plat;
 - 2. The construction plans conform to all applicable regulations pertaining to the construction and installation of public infrastructure improvements; and
 - 3. All outstanding application and review fees have been paid.
- E. Expiration. The approval of construction plans shall remain in effect for two (2) years after the date the construction plans were approved by the City Manager. If a public infrastructure permit has not been issued and construction of the project has not commenced during the two (2) year period, approval of the construction plans shall expire. For public infrastructure improvements that are associated with a final plat, approval of the construction plans shall remain in effect for the time that approval of the final plat is in effect and shall expire when approval of the final plat expires, unless an extension is granted.
- F. Extension. At the written request of the property owner or their authorized agent, the expiration date for the approval of construction plans may be extended by the City Manager for a period not to exceed six (6) months.
- G. Timing of Public Infrastructure Improvements.
 - 1. Completion prior to final plat recordation. For public infrastructure improvements associated with a proposed subdivision or development, except as provided below, completion of the improvements shall be in accordance with the approved construction plans and shall occur before an approved final plat is recorded, unless the obligation to construct public infrastructure improvements has been deferred and an improvement agreement is executed.
 - 2. Installation after final plat recordation. The property owner or applicant may request to defer the obligation to construct and install one (1) or more public improvements to serve the associated subdivision until after final plat recordation. The request shall be submitted in writing and specify what is being requested for deferral. The City Manager, at their discretion, may approve or deny the request to defer installation of public infrastructure improvements. Deferral of the obligation to install public improvements if granted shall be conditioned on execution of a Subdivision Improvement Agreement and provision of sufficient security.
 - 3. Off-Site Easements. All necessary off-site easements required for installation of off-site public improvements to serve the subdivision or development shall be acquired by the subdivider or developer and conveyed solely to the City by an instrument approved by the City.

Sec.2.16. Public infrastructure permit, inspections, and acceptance of public infrastructure

- A. Applicability. The provisions of this section apply to the construction of any public infrastructure improvements.
- B. Application Requirements. Any request for a public infrastructure permit shall be accompanied by an application prepared in accordance with the City's Development Manual.
 - 1. Applications for public infrastructure, subdivision entry features or any other permits and utility connections associated with a subdivision shall only be accepted and considered after the City has approved the final plat unless otherwise authorized by the City Manager.
- C. Processing of Application and Decision.
 - 1. An application shall be submitted to the City Manager. The City Manager shall review the application for completeness. The City Manager may request a review and recommendation from any other city department or consultant.
 - 2. Decision by the City Manager. The City Manager may approve, approve with conditions or deny the public infrastructure permit.
- D. Criteria for Approval. The City Manager shall apply the following criteria in making a decision on the public infrastructure permit:
 - 1. The application is consistent with the approved preliminary plat or the proposed final plat or replat, in the event that the public infrastructure improvements are in relation to a plat; and
 - 2. The application conforms to all applicable regulations pertaining to the construction and installation of public infrastructure improvements; and
 - 3. All outstanding application and review fees have been paid.
- E. Expiration. The approval of a public infrastructure permit shall remain in effect for two (2) years after the date the permit was approved by the City Manager. If construction of the project has not commenced during the two (2) year period, the public infrastructure permit shall expire. For public infrastructure permits that are associated with a final plat, approval of the public infrastructure permit shall remain in effect for the time that approval of the final plat is in effect and shall expire when approval of the final plat expires, unless an extension is granted.
- F. Extension. At the written request of the property owner or their authorized agent, the expiration date for the public infrastructure permit may be extended by the City Manager for a period not to exceed six (6) months.
- G. Inspections of Public Infrastructure Improvements.

1. Inspections. The City shall from time to time inspect the construction of all utility facilities and streets in the subdivision or development during the course of construction to see that they comply with the standards governing them. In this regard, free access to the subdivision or development shall be accorded the City by the applicant and their agents and employees. Inspection of the public infrastructure improvements shall be conducted by the City or its representatives. Construction shall be in accordance with the approved construction plans. Any significant change in design required during construction shall be subject to approval by the City Manager.
- H. Acceptance of Public Infrastructure Improvements.
1. Upon the completion of construction of any utility or public improvement, a public infrastructure improvements acceptance package shall be submitted in accordance with the City's Development Manual.
 2. Submission of as-built plans or record drawings. The City shall not accept dedication of required public improvements until the applicant has submitted detailed "as-built" record drawings in accordance with City requirements. As-built plans or record drawings shall be submitted in accordance with the City's Development Manual and shall be dated, signed and certified by the engineer in charge, showing all features as actually installed, including materials, size, location, depth of elevation, numbers, end of lines, connections, wyes, valves, storm sewer drains, inlets, and any other pertinent items as applicable.
 3. Acceptance of improvements. When the City Manager has determined that the public infrastructure improvements have been installed in accordance with the approved Construction Plans, the City Manager shall accept such improvements on behalf of the City. Acceptance of the improvements shall mean that the property owner has transferred all rights to all the public improvements to the City for use and maintenance. Upon acceptance of the required public improvements, the City Manager shall have a certificate issued to the property owner stating that all required public improvements have been satisfactorily completed.
- I. Maintenance and Warranty of Improvements.
1. Maintenance during construction. The developer shall maintain all required public improvements during construction of the development.
 2. Bond. The developer or owner shall covenant to warranty the required public improvements for a period of two (2) years following acceptance by the City of all required public improvements or following the date of plat recordation, whichever occurs later. All public improvements shall be bonded, and bond submitted to the City prior to plat recordation if applicable. The developer or owner shall provide a warranty bond in the amount of either:
 - a. 20% of the estimated cost of improvements as determined by the City Engineer; or
 - b. 20% of the actual cost of the improvements.

Sec.2.17. Subdivision improvement agreements

- A. Deferral of public improvements. The property owner or applicant may request to defer the obligation to construct and install one (1) or more public improvements to serve the associated subdivision until after final plat recordation. The request shall be submitted in writing and specify what is being requested for deferral. The City Manager, at their discretion, may approve or deny the request to defer installation of public infrastructure improvements. The City Manager may, for any reason, elect to present the deferral request to City Council for approval. Deferral of the obligation to install public improvements if granted shall be conditioned on execution of a Subdivision Improvement Agreement and provision of sufficient security.
- B. Obligations under agreement. Whenever public improvements to serve development are deferred until after recordation of the final plat, the property owner shall enter into a Subdivision Improvement Agreement and provide adequate security as determined by the City Manager. The Agreement shall be subject to review and approval by the City Manager and any other city department or consultant they deem necessary. The Agreement shall contain the following minimum provisions:
1. Covenants to complete the improvements no later than two (2) years after approval of the final plat, unless otherwise stipulated in the terms and conditions of the Improvement Agreement;
 2. Covenants to warranty the required public improvements for a period of two (2) years following acceptance by the City of all required public improvements, unless stated otherwise in the Improvement Agreement;
 3. Covenants to provide a warranty bond in the amount of 20% of the costs of the improvements for such period, unless stated otherwise in the Improvement Agreement;
 4. Provisions for participation in the costs of the improvements by the City, if authorization has been obtained from the City Council, and a performance bond for such improvements has been approved by the City and signed by all parties;
 5. Provisions for securing the obligations of the agreement in accordance with this ordinance; and
 6. Such other terms and conditions as are agreed to by the City and the property owner, or as may be required by this ordinance or other City regulations.
- C. Covenants to run with the land. The Subdivision Improvement Agreement shall provide that the covenants contained in the Agreement run with the land and bind all successors, heirs and assignees of the property owner. All existing owners and lienholders shall be required to execute the Agreement or provide written consent to the covenants contained in the Agreement.
- D. Security for Completion of Improvements.
1. Security. Whenever the property owner has entered into a Subdivision Improvement Agreement to defer installation of public improvements, the property owner shall provide sufficient security for completion of the required public improvements. The security shall be in the form of a cash escrow, letter of credit, a performance bond or surety bond provided by a licensed surety company, or other security as approved by the City Manager.

2. Amount and acceptability. The security shall be issued in the minimum amount of 125% of the estimated cost of completion that is approved by the City Manager for the required public infrastructure improvements. The terms of the security agreement shall be subject to the approval of the City Manager and the City Attorney.
3. Remedies. Where an Improvement Agreement has been executed and security has been posted and required public improvements have not been installed in accordance with the terms of the agreement, the City may:
 - a. declare the Agreement to be in default and require that all the public improvements be installed regardless of the extent of completion of the development at the time the agreement is declared to be in default;
 - b. obtain funds under the security and complete the improvements itself or through a third party; or
 - c. assign its right to receive funds under the security to any third party, including a subsequent owner of the development in exchange for the subsequent owner's agreement and posting of security to complete the public infrastructure improvements.

Section 3. Design Standards

Sec.3.1. Monuments and lot markers

- A. Monuments and lot markers shall be provided consistent with the requirements of the Public Works Specifications Manual.

Sec.3.2. Blocks

- A. The length, width and shape of blocks will be determined with due regard to:
 1. provisions of adequate building sites suitable to the special needs of the type of use contemplated (note that the City Council may require that the block and lot size bear reasonable relation to the planned use of the land);
 2. zoning requirements as to lot sizes and dimensions; and
 3. need for convenient access, circulation, control and safety of street traffic.
- B. In general, intersecting streets shall be used to determine the block lengths and widths, and shall be provided at such intervals as to serve cross traffic adequately, and to meet existing streets or customary subdivision practices.
- C. In general, block lengths along local or collector streets shall not exceed 1,400 feet or be less than 350 feet, and along arterials shall not exceed 1,800 feet or be less than 800 feet.
- D. A waiver to the standards of this section may be allowed in cases where physical barriers, property ownership or adjacent existing subdivisions create conditions where it is appropriate. The length may be increased or decreased to meet the existing conditions having due regard for connecting streets, circulation of traffic and public safety.

Sec.3.3. Lots

- A. Lot sizes and dimensions shall conform to the minimum requirements of the zoning district for which the property is zoned. The lot area shall be computed including all easements. Changes in the required lot sizes and dimensions may only be allowed through rezoning or through the granting of a variance by the Board of Adjustment. No lot shall be approved which does not meet the minimum requirements of the appropriate zoning district.
- B. Lot Frontage Requirement. Every lot shall have frontage on, and access to, a public or private street. A waiver may be granted to allow lots to have access through a public or private access easement for lots within a non-residential subdivision.
- C. Non-buildable lots under common ownership. Lots which are designated to be private open space, common areas, greenbelts, and drainage and intended to not be developed and will be owned and maintained by a homeowner's association or property owner's association may be approved with the plat. Non-buildable lots are not required to meet the zoning minimum lot dimensions.
- D. Flag lots. Flag lots are prohibited except through a plat waiver. In no case shall a flag lot have less than 20 feet of street frontage.
- E. Double frontage lots. Double frontage lots are prohibited except where essential to provide separation of residential development from arterial streets or to overcome specific disadvantages of topography and orientation. Double frontage lots require front setbacks on both frontages established in accordance with the underlying zoning regulations. Rear and side driveway access to arterials or limited access streets is prohibited and a plat creating such lots shall include vehicular non-access easements along such streets.

Sec.3.4. Access management

- A. Purpose. It is the intent of this section to prohibit the indiscriminate location and spacing of driveways while maintaining reasonable vehicular access to and from the street system as well as reduce conflicting turning movements and congestion and thereby reduce vehicular accidents.
- B. Shared and cross access.
 - 1. To facilitate access management and internal circulation, common access and cross access Easements are required between and across adjacent lots used, zoned, or planned for non-residential and mixed-use fronting on any street section unless the City Manager authorizes an exemption due to site constraints. Industrial development is not required to provide cross access.
 - 2. The use of common driveways shall require the dedication of a joint-use public or private access easement on each affected property.
 - 3. Properties which do not share a common driveway straddling a property line shall provide cross access easements to facilitate the flow of traffic between adjacent properties. Cross access shall begin at a driveway and extend side to side to adjacent properties and must connect to existing access points on adjacent properties where they exist.

4. The easement dedication shall be provided on the Final Plat when a public easement is used. Alternatively, a private access easement for access via neighboring property may be filed by separate instrument with the County if approved by the City Attorney and a filed copy forwarded to the City. When a private access easement is used, it shall be filed prior to recordation of the Final Plat or prior to issuance of a Certificate of Occupancy, whichever occurs later.
 5. The plat or easement instrument shall state that the easement shall be maintained by the property owner or a property owner's association.
 6. The easement shall encompass the entire width of the planned driveway and drive aisles.
- C. Driveway and access.
1. Driveways and access shall be provided consistent with the requirements of the Public Works Specifications Manual.

Sec.3.5. Sidewalks

- A. Requirement. Sidewalks shall be required along both sides of all streets throughout the City. Alternatively, publicly accessible trails may be installed separate from the street right-of-way providing connectivity to lots. All lots must have access to a sidewalk or trail.
- B. Location and width. Where sidewalks are installed, they shall be installed in accordance with the Public Works Specifications Manual and shall be of a minimum width as identified in this ordinance based on roadway classification. Sidewalks shall be placed in the right-of-way parallel to the street for the entire frontage(s) of the lot and shall be located adjacent to the property line. The City Manager may allow for alternative sidewalk or trail locations based on the existing character and development in the area.
- C. Timing of construction. Sidewalks shall generally be installed concurrently with the construction of the primary structure on a lot. Curb ramps and sidewalks on non-buildable lots shall be installed concurrently with street construction or prior to plat recordation if no street construction is required.
- D. Construction concurrent with street construction. If a street is constructed adjacent to non-buildable lots, such as open space, detention ponds, etc., then sidewalks should be installed concurrently with street construction.
- E. Corner Lot. Where sidewalks are installed on corner lots, sidewalks shall be installed along both street frontages and shall be extended to the curb with accessible ramps in accordance with current ADA and Texas Accessibility standards.
- F. Sidewalk obstructions. The required minimum sidewalk width cannot be obstructed. Mailbox clusters, kiosks of any character, street signs, above ground utility infrastructure, and other similar sidewalk obstructions shall be located outside of the minimum sidewalk width.

Sec.3.6. Alleys

- A. Alleys are optional in all subdivisions, provided that they conform to the standards and requirements of this ordinance.

- B. Intersections and Turns. All alleys must intersect streets at a 90 degree angle, or as close to a 90 degree angle as practicable and they must be approximately parallel to the streets on both sides. Alley intersections with another alley and sharp changes in alignment shall be avoided, but where two (2) alleys intersect, or an alley turns at an angle sharper than one hundred degrees (100°), a cut off of not less than ten (10') feet from the normal intersection of the property lines shall be provided.
- C. Alleys in residential areas designed for rear entry garages must be designed to the same standards as commercial alleys.
- D. Public Alleys Prohibited. All alleys shall be privately owned and maintained. No new public alleys shall be created unless a waiver is granted.
- E. Dead End Alleys. Dead end alleys are prohibited.
- F. Construction Standards. All alleys shall be constructed in accordance with the standards prescribed in the Public Works Specifications Manual.

Sec.3.7. Streets

- A. Street layout. The street layout shall be arranged to achieve the most desirable development of the entire neighborhood unit with appropriate consideration of creeks, drainage channels, wooded areas and other topographical features, which lend themselves to special treatment. Permits must be obtained from TxDOT for driveways and streets accessing any state highway. The proposed location of driveways must comply with all applicable City and State safety requirements.
- B. Relation to adjoining streets. Adjoining areas shall be continued and tied into the street layout.
- C. Projection of streets. When adjoining properties are not yet subdivided, the arrangement of streets shall provide for the proper projection of streets into the adjoining unsubdivided areas and will be required to comply with the neighborhood pattern or conform to transportation plans adopted by the City.
- D. Interior circulation streets. Adequate collector streets shall be provided for the circulation of traffic through the subdivision, and adequate local streets shall be provided to accommodate the subdivision.
- E. Dead-end streets and cul-de-sacs.
 - 1. Dead-end streets shall be prohibited, except as short stubs projected to be continued in future subdivisions or when designed as cul-de-sacs. Temporary turnarounds shall be provided on projected streets that exceed 150 feet in length from the nearest intersection. An easement shall be provided for areas of a temporary turnaround not located within the street right-of-way.
 - 2. Cul-de-sac streets shall not exceed 500 feet in length and shall have a turnaround of not less than 100 feet in diameter of ROW and 80 feet in diameter of pavement in single-family residential areas, 130 feet in diameter of ROW and 100 feet in diameter of pavement in all other areas. The diameter may be modified upon approval of the City Manager.

- F. Landscaped islands or similar will be reviewed on a case-by-case basis to ensure they are designed adequately for emergency vehicles and maintenance. Such islands shall be identified on the plat. A plat note shall be provided indicating that the island will be maintained by a homeowner association or similar entity. Any islands that are not maintained may be removed by the City and shall be removed at the expense of the entity responsible for maintenance, after due notice and the written recommendation of the City Engineer.
- G. Private streets.
1. Private streets must comply with the requirements of this subsection.
 2. Designation of private streets. The designation of interior circulation streets as private streets shall include at the time of preliminary plat submission the following:
 - a. Affidavit. The applicant shall provide an affidavit stating that prior to the conveyance of any lot within the subdivision a dedicatory instrument shall be filed in the public records of the county in which the subdivision is located, memorializing the establishment of a property owners' association that, inter alia, shall collect regular assessments and be authorized to collect special assessments that shall, in sufficient amounts to maintain, repair, and reconstruct the private streets.
 - b. Designation of private streets as lots.
 - i. Private streets shall be designated on the plat as separate lots.
 - ii. Lots designated as private streets shall not be required to comply with lot dimension requirements.
 - iii. No habitable structure, or structure requiring a certificate of occupancy, may be constructed on a lot designated as a private street.
 - iv. Plat note. The preliminary and final plat shall contain a plat note substantially compliant with the following:
 1. Private Streets. The lots assigned lot numbers _____, are designated as private streets which shall be dedicated to, and maintained by, a property owners' association. The Owner shall inform the purchaser of any lot within the subdivision that the streets are designated as private and that the property owners' association, and not the City shall be responsible for maintaining the private streets.
 - c. Design standards.
 - i. All private streets will conform to the same dimensional and construction standards as public streets.
 - ii. The area of private streets will not be included to meet minimum lot sizes.
 - iii. Access. Access will be allowed and provided for emergency vehicles and personnel, City staff personnel, and access to and within utility easements.
 - iv. Speed limits for private streets will be set according to the National Association of City Transportation Officials (NACTO) standards or the American Association of State Highway and Transportation Officials (AASHTO) standards.
 - d. Gated communities. Gated communities have the following additional requirements:

1. Streets Bordering Subdivisions. Existing streets often lie adjacent to but beyond the perimeter of property to be subdivided. Such streets exist because of some previous formal dedication (of right-of-way) or by prescriptive easement. All such streets bordering a subdivision shall be improved and/or rights-of-way dedicated, in accordance with standards described below:
 - a. The subdivider must dedicate at least one-half the additional right-of-way necessary to comprise the full street width required by this ordinance and in compliance with the most recently adopted Transportation Plan for the City, along that length of such street which directly borders the subject property to be subdivided. Dedication of more than one-half this additional increment may be required, in some instances, to maximize use of existing roadway and/or to ensure a consistent street alignment with a minimum of undesirable curvature.
 - b. The subdivider must pave one-half the additional increment of pavement necessary for compliance with the standards of this ordinance and the most recently adopted Transportation Plan for the City, along that length of street right-of-way which directly borders the subject property to be subdivided. If the subdivider widens existing pavement, the existing pavement shall be cut back a distance required by the Public Works Specification Manual to assure adequate subbase and pavement joint, before additional paving material is applied.
 - c. For TXDOT roadways, only right-of-way dedication is required. Improvements to TXDOT roadways shall only be required when indicated on a Traffic Impact Analysis or required by TXDOT.
- O. Emergency access.
 1. All residential subdivisions with single-family or two-family homes with more than 30 lots, or multiple adjacent subdivisions with more than 30 lots, shall have a minimum of two (2) locations accessing existing public streets. Access to existing public streets may be made through connection to a subdivision with private streets, provided that the proposed subdivision is made part of the POA or HOA which owns and maintains the existing private streets. The extent and location of all accesses is subject to review and approval by the City. The City Council may grant a waiver to allow this requirement to be met through an access easement.
 2. The City Council shall not permit lots or streets that would be surrounded by the flood water of a one hundred (100) year flood unless the area is accessible to high ground by at least one dedicated street elevated above the one hundred (100) year flood level.
- P. Emergency vehicle clearance.
 1. All roadways that serve emergency vehicles are required to have a minimum clearance of fourteen feet (14') to any overhead obstructions including, but not limited to, bridges, trees, canopies, awnings and signs.
 2. All roadways that serve emergency vehicles shall meet all applicable standards for width and turning radius per adopted city construction standards, other city codes, and the fire code.
- Q. Street and traffic control signs.

1. All street signs in a new subdivision, including street name, speed limit, stop and yield signs, etc. shall be paid for by the developer, and shall be designed and installed in accordance with the Public Works Specifications Manual. Traffic control devices required within the subdivision shall be installed in accordance with the latest revision of the Texas Manual on Uniform Traffic Control Devices for Streets and Highways.
 2. Any installation of speed control devices, such as speed bumps or humps, must also be approved by the City Manager to determine potential impact to emergency response vehicles.
- R. Roadway improvements.
1. All street improvements shall meet the current requirements of this ordinance, but in no case shall be less than the following:

MINIMUM ROADWAY IMPROVEMENT STANDARDS TABLE				
Road Classification	ROW Width	Pavement Width	Curbing	Sidewalk
Arterial (FM 2252, FM 3009)	120 feet	2@24 feet with 14 foot median	Curb & Gutter	5 feet
Collector	60 feet	38 feet	Curb	5 feet
Local Street	50 feet	26 feet	Curb	5 feet
Marginal Street	45 feet	26 feet	Curb	5 feet
Commercial Alley	24 feet	20 feet	None required	N/A
Residential Alley	20 feet	16 feet	None required	N/A

- S. Curb and gutter. Curbs and gutters shall be installed by the subdivider in accordance with this ordinance. Curbs and gutters shall be constructed in accordance with the Public Works Specifications Manual. The City Manager may waive the requirements for construction of curb and gutter or may approve an alternative curb and gutter construction.
- T. Utility Conduits. All new streets and alleys in subdivisions shall contain under-the-street conduits of sufficient size and spacing that gas and water extensions from mains to building sites can be provided without cutting cross trenches after street completion. Conduits shall be placed prior to the placement of street base materials. Directional boring shall be used in lieu of cutting existing streets except with prior approval of the Public Works Director.
- U. Street lights.
 - 1. Developers shall furnish satisfactory easements for installation of services to street lights as required by the City and any applicable electric utility provider.
 - 2. Street light number, type and size shall be determined by the City and any applicable electric utility provider and shall be designed to maximize the light directed toward the ground.
 - 3. Street lighting shall be provided at all intersections and street alignment changes greater than 45 degrees.
 - 4. The developer shall pay the cost of purchasing and installing all street lighting equipment and the cost of all street lighting services for a period of two (2) years or until such time as seventy percent (70%) of the lots being platted are developed, whichever is sooner. After such time a homeowners association, or similar entity, shall be responsible for the cost of street lighting services.
 - 5. A detailed lighting plan shall be submitted with the public infrastructure construction plans for review and approval by the City and any applicable electric utility provider.
- V. Coordination with TxDOT. The subdivider shall comply with all applicable Texas Department of Transportation (TxDOT) requirements concerning driveways, drainage and other related requirements. Prior to plat application submission for subdivisions fronting on TxDOT right-of-way, the subdivider shall review with TxDOT any changes or improvements that are being planned for that roadway. If such changes are planned, TxDOT can project the new right-of-way widths required for the planned roadway improvements and the subdivider shall comply with any requirements by TxDOT to implement such plans. This will enable the subdivider to provide necessary easement or right-of-way dedication on the plat to reflect the projected new right-of-way when presenting the plat to the City Council.

Sec.3.8. Traffic impact analysis

- A. Applicability. Every application for development within the city shall be accompanied by a Traffic Impact Analysis (TIA) Determination form provided in the development manual. The TIA Determination Form shall be utilized to determine if a TIA is required.
- B. TIA required. The threshold requirement for a TIA and the level of TIA required shall be based on a land use or combination of land uses that result in peak hour trips in accordance with the following:
 - 1. 100 or less peak hour trips generated – no TIA required
 - 2. 101 - 500 peak hour trips generated – Level 1 TIA required

3. 501 – 1,000 peak hour trips generated – Level 2 TIA required
 4. 1,001 or more peak hour trips generated – Level 3 TIA required
- C. TIA scope. If a TIA is required, the applicant shall meet with the city engineer to determine the scope for the study prior to beginning work on the TIA. The applicant shall be prepared, prior to the meeting with the city engineer, to discuss potential intersections to be evaluated, data assumptions or any other information required by the city engineer.
- D. TIA Study Area. The study area required for the TIA shall be based on the level of the TIA required. The city engineer may, at his/her discretion, require additional area to be included in the study area if deemed necessary to provide adequate review of the transportation network. The following identifies the minimum acceptable study area:
1. TIA Level 1 - The site area and the study area within a one quarter ($\frac{1}{4}$) mile radius from the boundary of the site.
 2. TIA Level 2 – The site area and the study area are within a one half ($\frac{1}{2}$) mile radius from the boundary of the site.
 3. TIA Level 3 - The site area and the study area are within a maximum of one (1) mile radius from the boundary of the site.
- E. TIA contents. The contents of the TIA shall be in conformance with the requirements of the Public Works Specification Manual.
- F. TIA revisions. It is recognized that the scope of the developer's plans may change from time to time. The monitoring reports may also demonstrate changes in the area street conditions and travel patterns within and around the city. Periodic updates to the TIA may be required to address these issues and identify changes to the level of service at study intersections and streets. These updates shall address modifications to the magnitude and timing of improvements recommended by the original TIA. Any TIA amendments must be acceptable to the city.

Sec.3.9. Water utility

- A. Installation of water facilities. All lots, tracts or parcels on which development is proposed shall be connected to a public water system which has capacity to provide water for domestic use and emergency purposes, including adequate fire protection. The developer shall install at his/her own cost and expense, adequate water facilities, including fire hydrants, in accordance with all applicable regulations of the State, the City and any other agency regulating public water systems.
- B. Fire Hydrants.
1. Fire hydrants are to be properly located so there will be a fire hydrant every three hundred feet (300') in non-residential areas and every five hundred feet (500') in residential areas.
 2. Any new fire hydrant is required to have a hydrant locator reflector (blue bump) installed in the roadway perpendicular to the hydrant.
- C. Individual wells.

1. Within the City Limits. New individual private wells within the City limits are generally prohibited. New wells for agricultural purposes on properties with an agricultural exemption and at least 10 acres in size may be allowed and require approval by City Council.
 2. Existing wells. Properties served by pre-existing water wells may continue to use those wells, but must connect to the public water supply system once water lines are available adjacent to the property. Once connected to the public water supply system, pre-existing water wells must either be disconnected or an approved backflow prevention installed.
 3. Compliance with other regulations. Installation, operations and maintenance of individual wells shall comply with City standards, regulations of the TCEQ, any other applicable state rules and regulations, and applicable regulations of groundwater conservation districts. In the event of conflict among these regulations, whichever is the most stringent shall apply.
- D. Alternative water sources. An alternative source of water within a development may be used for irrigation or other similar purposes, subject to approval by the City Manager and the obtaining of all appropriate permits from the City, State and any other applicable agency. An alternative water source may not be used for potable water supply under any circumstances. The design and construction of water system improvements and alternative water sources shall comply with the rules and regulations of the City, State or any other applicable agency.
- E. Extension of Lines. Extension of water lines shall be made along the entire frontage of the subdivision adjacent to a street. If the subdivision is not adjacent to a thoroughfare, the extension of utilities shall be accomplished in such a manner as to allow future connections to said utilities by new subdivisions. If due to physical constraints, new subdivisions will never be constructed beyond the proposed subdivision, the City Manager may waive the requirement for adjacent utility line construction at the time of final plat approval and prior to construction of the subdivision.
- F. Design and construction. All water facilities within a subdivision shall be designed and constructed to the standards as set forth by the water utility provider. Said facilities shall meet all state and federal regulations pertaining to approved public water systems including regulations regarding the preparation, submittal and approval of plans and specifications for water systems.

Sec.3.10. Wastewater utility

- A. Wastewater collection and treatment required. All lots, tracts or parcels on which development is proposed shall be served by an approved means of wastewater collection and treatment.
- B. Alternative wastewater systems. When a subdivision is not required to connect to a public wastewater system due to lot size or the granting of a plat waiver, an alternative wastewater system maybe be provided. The City Manager will make the final determination of the adequacy of the proposed system.
1. On-site sewage facilities (OSSF). The use of OSSF for the treatment and disposal of wastewater shall be subject to the approval of the City. The City Engineer may require a soils percolation test prior to approval. The minimum lot area for residential subdivisions shall be at least 30,000 square feet of and right-of-way dedications. OSSF shall be installed on each lot concurrent with any development thereon and the design of such system and the method of installation shall conform in all respects to the standards and specifications of the City, County and State design criteria for OSSF.

- C. Extension of lines. All laterals and sewer mains installed within a subdivision must extend to the borders of the subdivision as required for future extensions of the collection system, regardless of whether such extensions are required for service within the Subdivision. If due to physical constraints, a new subdivision will never be constructed beyond the proposed subdivision, the City Manager may waive the requirement for adjacent utility line construction at the time of final plat approval and prior to construction of the subdivision.
- D. Design and construction. All wastewater facilities within a subdivision shall be designed and constructed to the standards as set forth by the wastewater utility provider. Said facilities shall meet all state and federal regulations pertaining to approved public water systems including regulations regarding the preparation, submittal and approval of plans and specifications for wastewater systems.

Sec.3.11. Easements

- A. Utility easements. Utility easements including but not limited to water, wastewater, electrical, television, telephone/telecommunication, and natural gas shall be provided for the installation of utilities and appurtenances in accordance with the requirements of the City as determined by the City Manager. In general, these easements shall be in the front of residential development lots, but may be placed in an alley, if present.
 - 1. All new utility installations and appurtenances, including but not limited to electrical, gas, television, and telephone/telecommunication, shall be placed underground. The City Manager may grant a waiver to allow above ground utility installation when underground placement is deemed impractical due to physical constraints.
 - 2. Where adjacent to Texas Department of Transportation (TxDOT) highways, utilities should generally be located within separate utility easements outside the highway right-of-way. The City Manager may grant a waiver to this requirement if authorized by TxDOT and determined to be in the best interest of the City.
 - 3. All properties or portions of properties designated as utility easements may be utilized for the following purposes; utilities, including but not limited to water, wastewater, electrical, television, telephone/telecommunication, and natural gas, with all necessary and /or desirable lines, laterals and/or appurtenances thereto (the "Utilities"). Together with the right of ingress and egress over adjacent land to or from the easement for the purpose of constructing, reconstructing, inspecting, patrolling, operating, maintaining, repairing, and removing the Utilities; the right to place new or additional Utilities in the easement and to change the size thereof; the right to relocate along the same general direction of the Utilities; the right to remove from the easement all trees and parts thereof, or other obstructions, which reasonably endanger or may reasonably interfere with the efficiency or operations of the Utilities; and the right to place temporary structures for use in constructing or repairing Utilities.
 - a. The property owner retains the right to use all or any part of the easement for any purpose which does not damage, destroy, injure, and/or unreasonably interfere with the use of the easement. However, the easement shall be kept clear of all structures or other improvements.

- b. The Utility shall make commercially reasonable efforts to ensure that damage to the property is minimized and the Utility will at all times, after doing any work in connection with the Utilities, restore the property to the condition in which the property was found before such work was undertaken to the extent that such restoration is reasonable in accordance with the usual and customary practices.

B. Drainage easements.

1. General requirements. Natural waterways and channels should be used wherever practical to carry runoff. Any modifications to existing waterways and channels must be approved by the City Manager. Where a subdivision is traversed by a watercourse, drainageway, natural channel or stream, an easement may be required by the City Engineer conforming substantially to the floodway or channel limits of such watercourse, plus additional width as necessary for maintenance, channel improvements and future needs.
2. Enclosed systems. Storm drainage easements of 15 feet minimum width shall be provided for existing and proposed enclosed drainage systems. Easements shall be centered on the systems. Larger easements, where necessary, shall be provided as directed by the City Manager.
3. Open channels. Storm drainage easements along proposed or existing open channels shall provide sufficient width for the required channel and such additional width as may be required to provide ingress and egress of maintenance equipment, to provide clearance from fences and space for utility poles; to allow maintenance of the channel bank; and to provide adequate slopes necessary along the bank.
4. Overflow drainage. Storm drainage easements shall be provided for emergency overflow drainage ways of sufficient width to contain within the easement stormwater resulting from a 100-year frequency storm less the amount of storm water carried in an enclosed system.
5. Drainage or storm water channels and structures within easements shall be maintained by the developer or his/her assigns.
6. All properties or portions of properties designated as drainage easements may be utilized for the following purposes; drainage, detention, retention, water diversion, and sanitary control, including but not limited to walls, beds, embankments, spillways, appurtenances, and other engineered devices (the "Drainage System"). Together with the right of ingress and egress over the adjacent land to or from the Easement for the purpose of constructing, reconstructing, inspecting, patrolling, operating, maintain, repairing, and removing the Drainage System; the right to change the size thereof; the right to relocate along the same general direction of the Drainage System; the right to create and/or dredge a stream course, refill, or dig out such stream course, establish or change stream embankments within the easement, install storm sewer systems, culverts, water gaps, and protecting rails; the right to remove from the easement all trees and parts thereof, which reasonably endanger or may reasonably interfere with the efficiency of the Drainage System; and the right to place temporary structures for use in constructing or repairing the Drainage System.

7. With respect to the drainage system the intention is to improve conditions of sanitation and water drainage control on the property for the benefit of the property, adjacent property, and the community, but the City does not guarantee or warrant that such control work will be effective, nor does the City assume any additional liability whatsoever for the effects of flood, standing water, or drainage on or to the property, or any other property or persons that might be affected by a stream, wash, or gully in its natural state or as changed by the City.
- C. Other easements. Additional easements for utilities and appurtenances, infrastructure maintenance, and public safety may be required by the City Manager. These additional easements include but are not limited to sidewalk easements, utility easements, sight visibility easements, maintenance easements, and retaining wall easements.
- D. Plat notes. The City Manager may require notes on a subdivision plat necessary to describe and effect the establishment of required easements.
- E. Gates required in fences. All fences crossing an easement shall have double swing gates to allow ready access to the easement.

Sec.3.12. Drainage and stormwater

- A. General.
 1. Facilities required.
 - a. The subdivider shall provide an adequate storm drainage system to protect each lot throughout the subdivision from flooding. These drainage facilities may consist of a combination of natural features, swales, watercourse improvements, bridges and culverts, enclosed storm sewers and other man-made improvements to carry off stormwater within the subdivision. The drainage system shall use detention ponds, retention ponds and siltation ponds, individually or in concert, to control runoff and to protect downstream properties from any increase in flooding originating from the subdivision. The system shall be integrated with the overall drainage system of the city, and the design of the system must be approved by the City Manager in accordance with the requirements of this ordinance.
 2. Stormwater management.
 - a. Stormwater management shall provide for the temporary storage of peak rates of stormwater runoff. Runoff is then released at a controlled rate which may not exceed either the capacity of the existing downstream drainage systems or the predevelopment peak runoff rates of the subdivision site. Temporary storage facilities shall consist of any one or a combination of the following: detention, retention, extended detention, infiltration, or other methods acceptable to the City Manager. Stormwater management facilities shall be designed to reduce post-development peak-rates of discharge for the 2, 10, 25, 50, and 100-year storm events at each point of discharge from the subdivision.
 3. Construction Sequencing.

- a. After approval of the preliminary plat, infrastructure construction plans shall be accompanied by a comprehensive and detailed report and plan for the control of erosion and sedimentation. The report shall include a construction sequencing plan which details the proposed placement, maintenance and removal of temporary erosion controls, the slope stabilization techniques which are to be employed and the restoration measures, including vegetative types, which are to be employed as part of the process of subdivision development. The plan shall list and show the location of temporary erosion controls, show the physical details of the controls, and include a construction sequencing list which will govern the timing of the use of various controls in relation to distinct steps in subdivision construction. All elements of the erosion control and construction sequencing plan shall also be included in the final construction plans submitted with the final plat.
4. Land clearing restrictions.
 - a. No clear-cutting or rough-cutting of land shall be permitted until a preliminary plat has been approved by the City Council, except for the limited clearing and rough-cutting which is necessary for soil testing and surveying as required by this ordinance. No other clearing or rough-cutting shall be permitted except as necessary for construction of temporary erosion and sedimentation controls until these controls are in place and approved by the City Manager. Areas to be cleared for temporary storage of spoil or construction equipment, or for the permanent disposal of fill material or spoils, shall be provided with the preliminary plat. The natural vegetation within any water supply protection zone shall not be disturbed except for purposes consistent with the ultimate use of the land in that zone.
5. Enforcement of Erosion controls and clearing restrictions.
 - a. If a subdivider does not comply fully with an approved erosion control and construction sequencing plan, or violates the restrictions on land clearance in the preceding subsections, the City Manager shall notify the subdivider in writing that the City may correct the violation and revegetate the disturbed area at the subdivider's expense unless, within 30 days after the date of the notice, the subdivider complies, corrects the violation, provides the required erosion and sedimentation controls and provides continuing maintenance thereof acceptable to the City Manager.
- B. Required drainage study.
 1. The subdivider shall submit a master drainage plan with the Subdivision Master Plan. The master drainage plan should show the flow line of existing water courses, existing drainage structures, and ultimate destination of water.
 2. The subdivider shall submit a full drainage study with the preliminary plat. The drainage study shall provide the following information, for both existing and fully developed conditions, for the entire watershed drainage area upstream of the lowest point(s) in the subdivision:
 - a. The entire watershed drainage area(s), depicted on a 7.5 minute series USGS map.
 - b. The drainage area(s) within the subdivision, depicted on a topographic map with two-foot contour intervals.
 - c. Drainage systems in adjacent subdivisions.

- d. Composite runoff factors.
 - e. Times of concentration.
 - f. Related rainfall intensity factors.
 - g. 100-year flood flow quantities with the 100-year flood plain limits for the existing and fully developed watershed shown on the preliminary plat.
 - h. Preliminary street grades sufficient to determine high points, low points, and direction of runoff flows.
 - i. Proposed locations of inlets, storm sewers and culverts.
 - j. Proposed routing of drainage ways.
 - k. All proposed drainage easements, including width of easement and configuration of channel.
 - l. The calculations to determine the volume of proposed detention, retention, sedimentation ponds.
3. The above information shall be supplemented with narrative text describing the watershed and the subdivision, including their general soil conditions, downstream channel conditions, all weather access, and the presence of special flood hazard areas within the subdivision. The study shall be prepared by a professional engineer registered in the State of Texas. The drainage study shall be submitted along with the preliminary plat. The City Manager representative shall review the submission, verify that all ordinance requirements have been met, and forward his/her recommendations to the City Council.
 4. Subsequent plats shall be in conformance with the approved drainage study from the preliminary plat, otherwise the drainage study shall be updated and amended to reflect any subsequent changes. For plats without a preliminary plat or for which no drainage study was completed with the preliminary plat, a drainage study must be approved prior to approval of any final plat.
- C. Drainage system design standards.
1. General requirements. Drainage facilities shall be provided and constructed as specified by the City Manager and the Public Works Specification Manual.
 2. Use of streets and alleys as drainage facilities.
 - a. Alleys shall be designed to carry stormwater on at least a five-year frequency.
 - b. Streets may be used for stormwater drainage only if the calculated storm water flow does not exceed the height of the curb and the velocity does not exceed 10 feet per second. Streets should be designed to carry 100-year flood events.
 - c. Local streets shall be designed on a basis of at least a five-year storm frequency and all other streets on at least a ten-year frequency. Emergency vehicle access shall be preserved with a minimum of 11 feet of roadway width during a 2-year storm event.
 - d. Where streets are not capable of carrying storm water as required above, drainage channels or storm sewers shall be provided.
 - e. Pavement width shall not be increased beyond the width determined by the street classification solely to accommodate drainage.

3. Storm sewers.
 - a. Where storm sewers are provided or required, their design shall be based on a 100-year storm frequency and the design must be approved by the City Manager. For all ordinary conditions, storm sewers shall be designed on the assumption that they will flow full under the design discharge; however, whenever the system is placed under a pressure head or there are construction, turns, submerged or inadequate outfalls, or other obstacles, the hydraulic grade line shall be computed and plotted in profile. In all cases adequate outlets shall be provided, and no storm sewers shall be less than 24 inches in diameter.
4. Street inlets to storm sewers.
 - a. The entire 25-year discharge shall be picked up at the point where the street can no longer handle the runoff flowing curb full. No allowance shall be made for overruns or partial street flows combined with storm sewer flows at initial pickup points. Street discharges, after initial pickup, may be based upon the street classification for frequency required.

Sec.3.13. Flood hazards

- A. General Policy. All subdivisions shall conform to the "Flood Disaster Protection Act of 1973," Public Law 93-234, and the latest revisions thereof, the City's Flood Damage Prevention Ordinance as amended, and policies as dictated by the Federal Emergency Management Agency shall be adhered to.
- B. Flood Plain Designations and General Restrictions.
 1. Federal flood plains are based on a 100-year frequency discharge and apply only in those areas where official Federal Emergency Management Agency maps have been prepared; surface profile studies are available for the City and its extraterritorial jurisdiction. Until a regulatory floodway is designated, no new construction, substantial improvements, or other development (including fill) shall be permitted in an area having special flood hazards as defined by the City's flood damage prevention ordinance as amended, unless it is demonstrated that the cumulative effect of the proposed development, when combined with all other existing and anticipated development, will not substantially increase the water surface elevation of the 100-year flood at any point within the City's subdivision jurisdiction.
- C. Flood hazards to water and wastewater system.
 1. New or replacement water supply systems and/or wastewater systems shall be designed to minimize or eliminate infiltration of flood waters into the systems and discharges from the systems into flood waters. On-site waste disposal systems shall be located to avoid impairment of them or contamination from them during flooding.
- D. Review of proposed subdivision flood hazards. Proposed subdivisions shall be reviewed to ensure that:
 1. All such proposals are consistent with the need to minimize flood damage;
 2. All public utilities and facilities, such as sewer, gas, electrical, and water systems are located, elevated, and constructed to minimize or eliminate flood damage; and
 3. Adequate drainage is provided so as to reduce exposure to flood hazards.

Sec.3.14. Parkland dedication requirements

A. Purpose.

1. The purpose of this section is to provide for the adequate provision of parkland and open space to meet the needs of a growing City population; for improvements to existing parkland; for establishment, maintenance and operation of a Parkland Dedication & Improvement Fund; establish requirements and procedures for governing required dedications of parkland or improvements to existing parkland by subdividers of land; and for cash payments-in-lieu of land by subdividers of land in certain cases.
2. It is hereby declared by the City Council that recreational areas in the form of parks and open spaces are necessary and for the public welfare and that the only adequate procedure to provide for parkland and park improvements is by integrating such a requirement into the procedure for planning and developing property or subdivisions in the City, whether such development consists of new residential construction on vacant land or the addition of new dwelling units on existing residential land. It is the policy of the City to require subdividers of residential subdivisions and lots to provide for parkland and park facilities at the time of development approval in proportion to the need for such improvements created by the developments and in proportion to the benefits received from contribution of such facilities.

B. Applicability. The parkland dedication and park development requirements of this section shall be applicable to every residential and multifamily subdivision developed under the provisions of this ordinance, whether such subdivision consists of new residential construction on vacant land or the addition of new dwelling units on existing residential land, within the City limits and extraterritorial jurisdiction (ETJ).

C. Parkland design requirements.

1. Compliance with the city master plan. Any land to be dedicated to meet the requirements of this article shall be reasonably located and adaptable for use as a public park and recreation facility as defined by the city master plan. The shape of the parcel or tract of land to be dedicated should be appropriate for public parks and recreation purposes.
2. General location. The location of parkland may be required at the edge of a subdivision so that additional land may be added at such time as adjacent land is subdivided or acquired for public use. Otherwise a centralized location is preferred.
3. Usable land. At least fifty percent (50%) of proposed parkland dedication site shall be level, well drained and suitable for open play. Such land shall be located outside of any one hundred (100) year floodplain or any other special flood zone identified on the most recently approved FEMA FIRM map and shall not exceed five percent (5%) slope.
4. Access. Access to parkland designated on a subdivision plat shall be provided by the dedication of at least 200 feet of street frontage in a manner satisfactory to the City, preferably at the corner of two (2) intersecting streets. When the land abutting the designated parkland is developed, the subdivider of such abutting land shall furnish and pay for all paving of all abutting street frontage.

5. Utilities. Water and wastewater connections shall be readily available at the park site with water and wastewater lines located along the street frontage. The applicant must demonstrate to the satisfaction of the City that sufficient utilities are available to serve the park.
 6. Drainage improvements. Detention ponds and/or other drainage facilities that serve the subdivision shall not be constructed in areas that are to be dedicated as parkland.
 7. Floodplain. Every acre of proposed dedicated parkland located within the floodplain or other special flood hazard area shall count as one-half (½) acre of land towards the total parkland dedication requirement.
 8. Trails. Dedication and improvement of linear trails, by dedication of land or through an easement, in accordance with adopted City plans is encouraged. Such land can be within a floodplain so long as it is developable and appropriate for an adequate trail per accepted trail standards.
- D. Dedication and improvement.
1. Land dedication. The subdivider of a residential (including multifamily) subdivision shall dedicate to the City developed improved parkland in the amount as established within the fee schedule adopted by the City Council. Parkland shall be shown on the final plat establishing a residential (including multifamily) subdivision and shall contain the dedication of an area of land for park purposes meeting the requirements set out in this section.
 2. Development of areas smaller than three (3) acres. No plat showing a dedication of less than three (3) acres for a public park shall be approved by the City Council unless it is determined by the Council that a smaller tract would be in the public interest, or that additional contiguous land will be reasonably available for dedication to or purchase by the City. If no land for parkland is being required by the City due to size or location, the subdivider shall be required to pay to the City the applicable cash payment-in-lieu of land and improvements.
 3. Improvements. A subdivider dedicating parkland shall improve the public parkland with improvements approved by the City Manager. The minimum value for the improvements should be roughly proportionate to the amount the subdivider would be required to pay as fee-in-lieu for parkland development if they were not dedicating land. Design, specification, and construction of the improvements shall be subject to review and approval by the City. No final plat shall be recorded for any subdivision in which completion of the required improvements has not been accepted by the City unless a parkland improvement agreement has been approved and executed with an adequate financial surety provided.
- E. Fee-in-lieu.
1. Right to request waiver of dedication requirements. A subdivider obligated to make a dedication of land may request the City waive the required dedication of land, in whole or in part, and to accept a cash payment-in-lieu of land dedication. Any request for a waiver to the land dedication requirements shall be subject to review and approval by the City Manager. The City Manager may, for any reason, elect to present the waiver request for approval to the City Council.

2. Required fee-in-lieu of land dedication and improvements. Any subdivider who is required to make a cash payment-in-lieu of land dedication and improvements or who is granted a waiver in accordance with this ordinance, shall make a cash payment-in-lieu of land and improvements in accordance with this section. The amount of such cash payment-in-lieu of land shall be calculated by multiplying the number of dwelling units proposed to be established by the plat times the amount per dwelling unit as established in the fee schedule set from time to time by the City Council. A cash payment-in-lieu of land and improvements shall be made prior to the recordation of the final plat for single family residential uses and prior to the issuance of a building permit for multifamily developments.
 3. Additional dwelling units. The addition of new dwelling units increasing the total number of dwelling units on existing residential land (including multifamily) shall be required to pay a fee-in-lieu for parkland dedication and improvement. Dedication and improvement of parkland or a fee-in-lieu for parkland dedication and improvement is not required for the addition of an accessory dwelling unit.
- F. Parkland Dedication & Improvement Fund.
1. The City shall reserve all fee-in-lieu of payments and any accrued interest from the fee-in-lieu of parkland dedication or fee-in-lieu of parkland improvement in a separate account from the general funds of the City. This fund shall be known as the Parkland Dedication & Improvement Fund.
 2. The City shall deposit sums collected as cash payments-in-lieu of land and cash payments-in-lieu of improvements in the Parkland Dedication & Improvement Fund. The City shall expend such funds collected for the acquisition of land or for the improvement of existing parks on a first in, first out basis.
 3. The City shall maintain records detailing the receipts and expenditures for the Parkland Dedication Fund. All funds deposited as credit for fee-in-lieu of parkland dedication or improvement shall be utilized for the acquisition of new parkland and/or the development of new or existing parkland within the City.
- G. Parkland dedication procedure.
1. Dedication procedures. The owner of property for a residential subdivision shall be required at final plat approval to dedicate parkland. Dedication of parkland shall be evidenced by a formal dedication on the plat to be recorded. The land so dedicated and conveyed shall not be subject to any reservations of record, encumbrances of any kind, or easements, which in the opinion of the City will interfere with or materially increase the cost of making such land available for parks or recreational purposes.
 2. Right to accept/reject land. If the City determines that sufficient park area is already in the public domain within proximity of the proposed development, or if the recreation needs for the area would be better served by expanding or improving existing parks, the City has the right to accept the dedication or to refuse same and require a cash payment-in-lieu of land and improvements.
 3. Development of Subdivision in Phases. If a subdivision is to be developed in phases and the final platting of the park area to be dedicated is to be included in a future phase, then the subdivider shall be required to enter into a Parkland Improvement Agreement and provide sufficient security for the land and improvements.

- H. Parkland Improvement Agreement. The property owner or applicant may request to defer the obligation to dedicate parklands and/or develop parklands until after a final plat recordation. The request shall be submitted in writing and specify what is requested for deferral. Deferral of the obligation to dedicate parkland and/or develop parklands shall be conditioned on execution of a Parkland Improvement Agreement and provision of sufficient security. The City Manager may approve or deny the request to defer obligations to dedicate parkland and/or develop parklands. An Agreement may be required for phased subdivisions where the parkland dedication is placed in a future phase.

DRAFT